

# BUCKINGHAM MFG.

## BUCK QUICK CONNECT CLIMBER PADS

### MODEL NO. 3502K1 & 35021K1 series – Cushion Climber Pads with Quick Connect Buckles

Warning: Do not use this product if you cannot understand and follow the instructions and warnings that come with it and complete all necessary functions.

Buckingham Quick Connect Climber Pads are shown below. These pads are not displayed to scale.

(Front Side Shown)

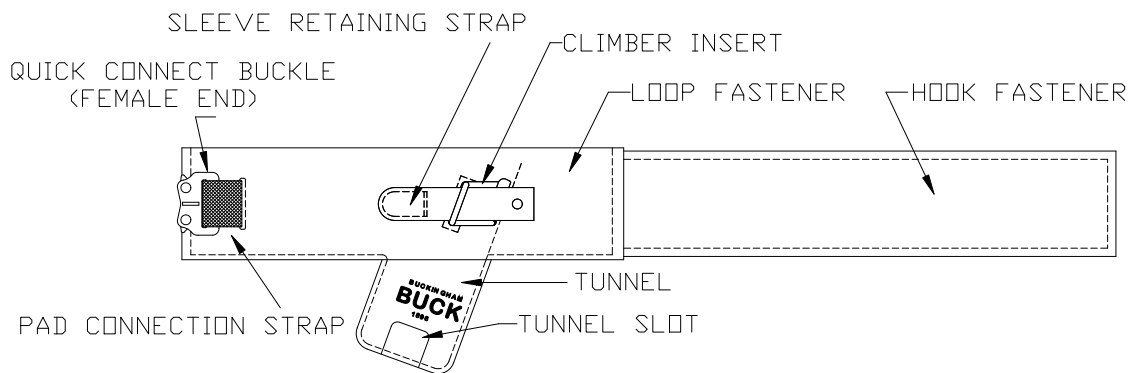

(Back Side Shown)

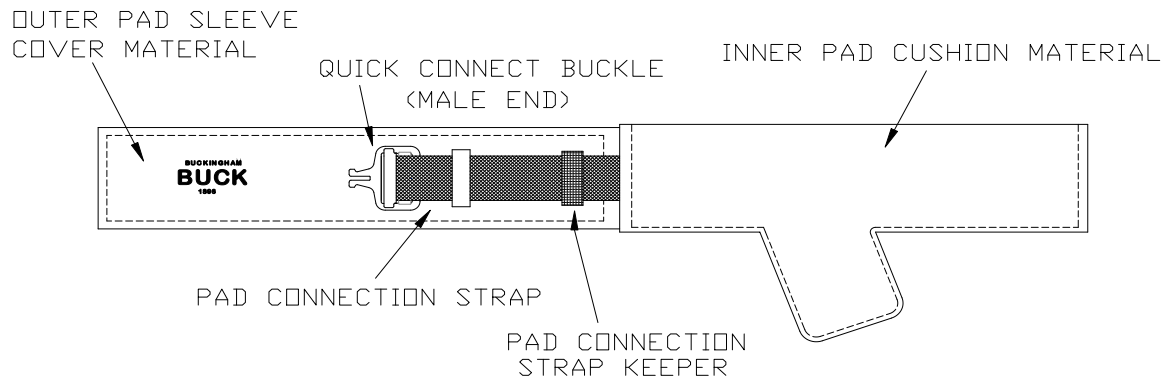

## INSPECTION

Quick Connect Climber Pads must be inspected before each use as follows:

- Inspect to ensure the pads and quick connect buckles are properly attached and in good condition.
- Ensure there are no missing, loose, or bent rivets.
- Ensure climber pad is free of broken, pulled, or frayed stitching.
- Inspect to ensure hook and loop fasteners are not worn or excessively dirty and that the hook fastener properly adheres to the loop fastener.
- Ensure no webbing cuts, kinks, abrasions, burns, excessive swelling, excessive wear, discoloration, cracks, charring, broken fibers, loose stitching, chemical or physical exposures.

If any evidence of excessive wear or deterioration as outlined is observed, immediately cease use, destroy the product, and replace it with new equipment. Should any unusual conditions not outlined above be observed, or you have reasonable doubt about a particular condition, remove the equipment from service and notify your Supervisor, Safety Director, or contact Buckingham Mfg. (1-800-937-2825) for clarification. Failure to carefully and completely inspect your equipment could result in serious injury or death.

**OVER**

## ASSEMBLING PAD TO CLIMBER

1. Adjust the overall length of the climber by sliding the adjustable climber sleeve to the desired position on the climber shank. Buckingham recommends the top of the pad be adjusted 1/2" below your projecting knee bone (Fig A). Slight adjustment up or down may be needed based on your particular climbing style to reach a maximum level of comfort.
2. Once at proper height, align the holes of the climber shank to the holes in the climber sleeve.
3. Insert the barrel nut through the hole in the back side of the sleeve and through the leg iron. Insert the screw through the climber sleeve and climber and thread into the barrel nut.
4. The sleeves must be properly attached to the climber leg irons using the appropriate supplied hardware (screws and barrel nuts) and two points of attachment (two fasteners per climber). Tighten sleeve screw fasteners until snug. Do not over tighten.
5. Ensure the correct climber (Left / Right) is paired with the correct pad (Left / Right). Climber pad designation is located on the tunnel of the pad sequentially after the product number.
6. Squeeze the pad so the tunnel protrudes outward, away from the pad.
7. Properly orient the climber and push the sleeve (attached to climber) from the bottom upward until the sleeve loop is exposed in the tunnel slot and contained within the climber pad climber insert.
8. Slide the sleeve retaining strap under the climber sleeve loop and climber pad insert loop and pull sleeve retaining strap through both loops.
9. Firmly adhere the sleeve retaining strap to the loop fastener on the pad.
10. Wrap the hook fastener of the outer pad sleeve cover over the loop fastener of the climber pad so that the hook fastener portion covers the sleeve retaining strap and adheres to the loop fastener on the pad. Press firmly to increase the adhesion of the hook and loop fasteners.



## ATTACHING QUICK CONNECT CLIMBER PAD TO YOUR LEG

1. Place your foot on the stirrup of the climber with suede material facing toward the inside of your leg.
2. Connect the male end of the Quick Connect Buckle to the female end (Fig. B). Never rely solely on the feel or sound of a Quick Connect Buckle engaging.
3. Tighten the pad connection strap by pulling the free end of the strap away from the Quick Connect Buckle. Tighten the strap so that the pad is snug to your leg, but never so tight as to restrict circulation.
4. Move the plastic keeper towards the free end of the pad connection strap to contain excess strap. If needed excess strap can be tucked under the Web Strap Keeper on the pad (Fig. C).
5. Climber Pads must always be used in combination with properly adjusted climber foot straps to attach climbers to your legs. Never use a Climber Pad without a climber foot strap (Fig. D).
6. Attach and fasten the climber foot strap after attaching the pad to your leg. (Fig. D) See Manufacturers Instructions regarding the use of climber foot straps.

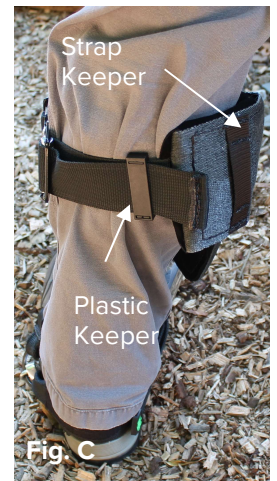

## CLEANING

Proper maintenance and storage of your equipment will prolong its useful life and contribute toward its performance.

**OVER**

Nylon should be cleaned with mild soap and water and be allowed to air dry thoroughly without using excessive heat. Do not use any type of corrosive substance or acid, which will gradually eat away the fabric.

Clean hook & loop fasteners with a soft bristle brush.

Clean suede pad material by removing surface dirt with a clean cloth dampened (not wet) with water and allow to air dry.

The Quick Connect Buckle may be cleaned by using a cotton swab, limited air pressure or dipping it into a container of water to remove fine particles and any foreign matter which may enter the female end of the buckle and prevent proper engagement and function. The exterior of the buckle should be dried with a clean cloth. The inside of the receptor end of the buckle should be air-dried and re-lubricated.

Lubricate pawls of the Quick Connect Buckle weekly or as often as required to maintain smooth operation (no binding) with a lightweight lubricant such as WD-40®. Wipe any excess lubricant off with a clean dry cloth.

## STORAGE

Store Quick Connect Climber Pads in a manner as to preclude damage from environmental factors such as temperature, light, UV, excessive moisture, oil, chemicals and their vapors or other degrading elements.

### For your information and attention:

This style of Quick Connect Buckles may unintentionally disengage under the condition outlined below:

If the pawls of the buckle do not freely rotate, proper engagement of the tab end to the receptor end of the buckle will be hindered / restricted. If as a result of the users movements or through contact with an obstruction during the course of his/her work, one of the two pawls of the receptor end of the buckle is depressed while tension is induced on the strapping attached to the buckle, the potential exists that disengagement of the tab end of that side from the pawl may occur. If that position is maintained and again through the users movements or contact with an obstruction the opposite side pawl is depressed, the tab end of the buckle may totally disengage from the receptor end.

To eliminate the potential for this condition, you the user should:

1. Inspect your equipment before each use as you would for all safety equipment. Equipment should be replaced if you have any question / doubt about it being safe for use.
2. Always position the buckles of your equipment so that contact with obstructions is avoided.
3. Test the pawls on your Quick Connect Buckles to ensure they freely rotate and return back to their original position. If any pawl does not freely rotate, the buckle should be (a) cleaned as outlined below to ensure there are no obstructions inside the buckle hindering its intended function and (b) lubricated with a lightweight lubricant such as WD-40®. as recommended for locking snaphooks. If the pawl still does not freely rotate, you should contact Buckingham Mfg. at the telephone number outlined below and request a Returned Goods Authorization Number for immediate return of your equipment for our inspection and/or buckle replacement.
4. Ensure the receptor end and tab end of the Quick Connect Buckle is fully connected with both locking pawls engaged. When the two halves are properly attached together, a clicking sound should be heard. Ensure that the pad connection strap is pulled through the buckle and tighten until it is snug but comfortable, thus ensuring complete engagement.

## WARNINGS

- Completely read, understand, and follow all instructions, warnings, and guidelines pertaining to this and all associated equipment before use. Failure to do so could result in your serious injury or death.
- Buckingham climber pads are not intended for, and not be used by, individuals not properly trained. Use by such persons could cause a fall and result in serious injury or death.
- Use equipment for its intended purpose only.
- Only Buckingham Mfg. Co. or those people authorized in writing by Buckingham Mfg. Co. may make repairs / modifications to this equipment.
- Climber accessories must be in good condition. Material shall be kept clean. Climbing equipment that shows signs of excessive wear, or cracking of components, should be immediately discarded.
- No equipment lasts forever. Therefore, should you have any doubt about the safety of your equipment, replace it.
- Product covered under these instructions / warnings should not be resold / redistributed or re-used after use by original user as assurance cannot be granted that a used product meets criteria of applicable standards and is safe for use to a subsequent user.
- Ensure proper fit / size of product before use. This product cannot be returned unless it is in new / unused condition.

## OVER

## **STATEMENT of OBSOLESCENCE:**

Precise “useful life expectancy” or “shelf life” for this product is not specified, as the degree of use, conditions of use, and the degree of care and storage determines useful life. All users maintain responsibility to select proper equipment for the job, be properly trained in its use, and ensure all personnel support equipment passes inspection before each use. Upon evidence of defects, damage or deterioration, all equipment shall be removed from service immediately and tagged or marked as unusable or destroyed. Additionally, all equipment shall be inspected on a regular basis not to exceed one year by a Competent Person, as defined by OSHA/ANSI, to verify that the equipment is safe for use. In the event of any question or concern regarding the condition of such equipment, users shall remove the equipment from service for further inspection. All users must comply with OSHA/ANSI/ASTM standards prior to and in using such equipment. For more information regarding safe and appropriate use of equipment, please contact Buckingham Manufacturing at 1-800-937-2825.

## **INTERNATIONAL USERS:**

Notwithstanding the above, please know that certain international jurisdictions require manufacturers of equipment to provide customers with a maximum useful lifespan (sometimes referred to as a “Statement of Obsolescence”). To the extent required, Buckingham personal protective equipment manufactured from synthetic fiber materials including but not limited to items such as webbing and/or rope are subject to a maximum useful lifespan of ten (10) years from the date of manufacture. As stated above proper usage, storage, maintenance, and care impacts the useful lifespan of equipment. Extreme circumstances may require that product must be retired after only one use. This statement is made in conformance and compliance with BS EN 365:2004. International users must ensure that product inspections are completed by Competent Persons as defined by international standards including but not limited to British Standard (“BS”). If equipment fails any inspections, it must be immediately withdrawn from service and destroyed. For more information regarding safe and appropriate use of equipment, please contact Buckingham Manufacturing at 1-800-937-2825.

## **OUR GUARANTEE:**

We guarantee the equipment we manufacture to be free from defects in material and workmanship. We will repair any equipment deemed to be defective which is returned to us by the original purchaser. However, this guarantee is void if any product is changed or altered in any way, or if the product is used in a manner other than for which it is intended. This express guarantee supersedes all other expressed or implied guarantees, obligations or liabilities. There are no implied warranties of merchantability or fitness for a particular purpose and as such, all implied warranties are specifically disclaimed.

## **LIMITATION ON LIABILITY:**

In no event will Buckingham or buyer be liable to the other for lost revenues, lost profits or any other indirect, consequential, special or punitive losses or damages, however caused, whether in action for breach of contract, strict liability, tort, or otherwise, even if advised of the possibility of such losses or damages. In no event will Buckingham’s liability exceed the total amount paid by the buyer to Buckingham for the product or equipment giving rise to such claim(s).

Please see other terms and conditions relating to this product at <https://buckinghammfg.com/terms-conditions/>

## **REGISTRATION:**

Before use of the product, ensure to register and confirm the product at [www.buckinghammfg.com/register](http://www.buckinghammfg.com/register).

**BUCKINGHAM MFG.**  
BINGHAMTON, NY  
1-800-937-2825  
[www.buckinghammfg.com](http://www.buckinghammfg.com)