



BUCKINGHAM MFG.

1-11 Travis Ave., Binghamton, NY 13904
Tel 1-800-937-2825 Fax (607) 773-2425
e-mail: sales@buckinghammfg.com

OPERATION AND MAINTENANCE MANUAL FOR BUCKINGHAM FALL PROTECTION AND RESCUE SYSTEM FOR CONFINED SPACE

TRIPOD SYSTEM

ITEM	FEET	MODEL NO.	SERIAL NO.
<input type="checkbox"/>	<input type="text"/>	Three Way Unit-P/N 5000	<input type="text"/>
<input type="checkbox"/>	<input type="text"/>	Tripod-P/N 5003 / 50039	<input type="text"/>
<input type="checkbox"/>	<input type="text"/>	Personnel & Material Winch P/N 5010	<input type="text"/>

WARNING! DO NOT USE THIS PRODUCT IF YOU CANNOT UNDERSTAND AND FOLLOW THE INSTRUCTIONS AND WARNINGS THAT COME WITH IT AND COMPLETE ALL NECESSARY FUNCTIONS. YOU MUST READ AND FULLY UNDERSTAND OR, HAVE THESE INSTRUCTIONS AND WARNINGS EXPLAINED TO YOU BEFORE USING THIS EQUIPMENT. FAILURE TO OBSERVE THE LIMITATIONS, CAUTIONS AND WARNINGS IN THESE INSTRUCTIONS CAN CAUSE A LOSS OF PROTECTION AND AN EXPOSURE TO A FALL FROM WHICH SERIOUS INJURY, DISABILITY OR DEATH MAY RESULT!

PLEASE KEEP THESE INSTRUCTIONS AVAILABLE FOR IMMEDIATE REFERENCE. IF YOU HAVE ANY QUESTIONS ABOUT ANY PART OF THESE INSTRUCTIONS PLEASE CONTACT BUCKINGHAM MANUFACTURING COMPANY - TEL (607) 773-2400 OR FAX (607) 773-2425 IMMEDIATELY FOR CLARIFICATION.

GENERAL INFORMATION

Entering confined space often involves the risk of a vertical free-fall hazard when climbing down or being lowered into fixed structures, along with the possibility of toxic air or insufficient oxygen supply. Venting and testing procedures are essential prior to entry into a confined space.

The **TRIPOD SYSTEM** is designed for confined spaces such as manholes, tanks, and other confined areas, where fall protection and retrieval rescue capability is required.

Recommend types of Tripod systems: A, B, and C.

Recommended when:

System A:

Tripod 7' or 9'	P/N 5003 / 50039
Three-Way Recovery Unit	P/N 5000
Personnel & Material Winch	P/N 5010
Confined Space Harness	
Pulleys (2)	P/N 5007B1
Carabiner (2)	P/N 5005

Lowering and raising a worker in a confined space that doesn't have a ladder.

System B:

Tripod 7' or 9'	P/N 5003 / 50039
Personnel & Material Winch	P/N 5010
Pulley	P/N 5007B1
Carabiner	P/N 5005

When it is necessary to lower or raise equipment or materials in a confined space.

System C:

Tripod 7' or 9'	P/N 5003 / 50039
Three-Way Recovery Unit	P/N 5000
Confined Space Harness	
Pulley	P/N 5007B1
Carabiner	P/N 5005

Working in a confined space that has a ladder.

Designation of the system components

Tripod P/N 5003 / 50039

The Tripod P/N 5003 / 50039 is a portable, lightweight high-strength anchor point for Buckingham confined space and rescue equipment (Figures 1 and 2). The major parts of the Tripod are illustrated and described in the Tripod section (pages 20-26).

Three-Way Unit P/N 5000 (see technical specifications, pages 15-16).

The Three-Way Rescue and Recovery Unit is designed for use in confined spaces such as manholes, tanks, and other confined areas where fall-arrest and retrieval rescue are important.

The Three-Way Rescue and Recovery Unit provides three functions:

- 1) a braking action if a worker falls (fall-arrest)
- 2) a means for a topside worker to raise another worker (retrieval)
- 3) a means for the topside worker to reverse direction, if for any reason the worker becomes wedged while retrieval is in progress. The topside worker can reverse direction allowing the worker to be lowered and repositioned before continuing with the retrieval.

Personnel Winch P/N 5010 (see technical specifications, pages 16-17)

The Personnel Winch P/N 5010 is designed to lower or raise personnel in confined spaces with or without the ladder or other means of fixed descent/ascent. The winch can also be used to lower or raise materials.

The Personnel Winch has a primary brake which holds loads in place when raising/lowering is stopped or when the crank is released. In addition, the Personnel Winch has a secondary brake system. In the case of a freewheel, the centrifugal system is automatically activated.

The Personnel Winch is furnished with a cable tensioner. The cable tensioner helps keep the cable even and level on the drum to reduce stress and wear.

System A is recommended **if a ladder or other fixed structure is not available**

(Fig. 1) and a worker is to be lowered into or raised out of a confined space. In this situation, as OSHA requires, the worker must always be attached to two lifelines, one from the Personnel & Material Winch, the other from the Fall Protection and Recovery Unit (P/N 5000, Three-Way type). The Three-Way Fall Protection and Recovery Unit is never to be used routinely for lowering or raising a worker, only for fall protection and rescue operations. Only the Personnel & Material Winch is meant to be used to raise and lower a worker in conjunction with Three-Way type Unit. The Personnel & Material Winch (P/N 5010) must be used as a primary work line for lowering and raising. The Personnel & Material Winch can also be used for material handling.

System B is recommended when it is necessary for equipment or materials to be lowered into or raised out of a confined space. In this situation the Personnel & Material Winch (P/N 5010) should be used. Systems A or C must still be used anytime a worker is needed to be lowered or raised in a confined space. The working load limit of 300 lbs. also applies for material and equipment handling.

System C is recommended in the situation where a ladder or other means of descent and ascent is in place, and a worker doesn't need to be lowered by a Personnel Winch, the worker must still be attached to an independent lifeline such as the Three-Way (P/N 5000). Although this unit has both fall-arrest and raising and lowering capability, at no time must the rescue/recovery device be used for routine raising and lowering.

The Buddy System (two workers) must always be used with the Tripod System (Fig. 1 and Fig. 2).

WARNING: Equipment must NOT be installed, operated, or inspected by anyone who has not read, understood, and followed all instructions contained in this manual. Failure to observe these instructions could lead to serious injury or death. Training and instruction review should be repeated at regular intervals by the user and his or her employer.

WARNING: Never attempt to adjust, repair or modify any parts or components of this Tripod System. For prompt repair or re-certification, return the component(s) to BUCKINGHAM MANUFACTURING COMPANY, 1-11 TRAVIS AVE., BINGHAMTON, NY 13904

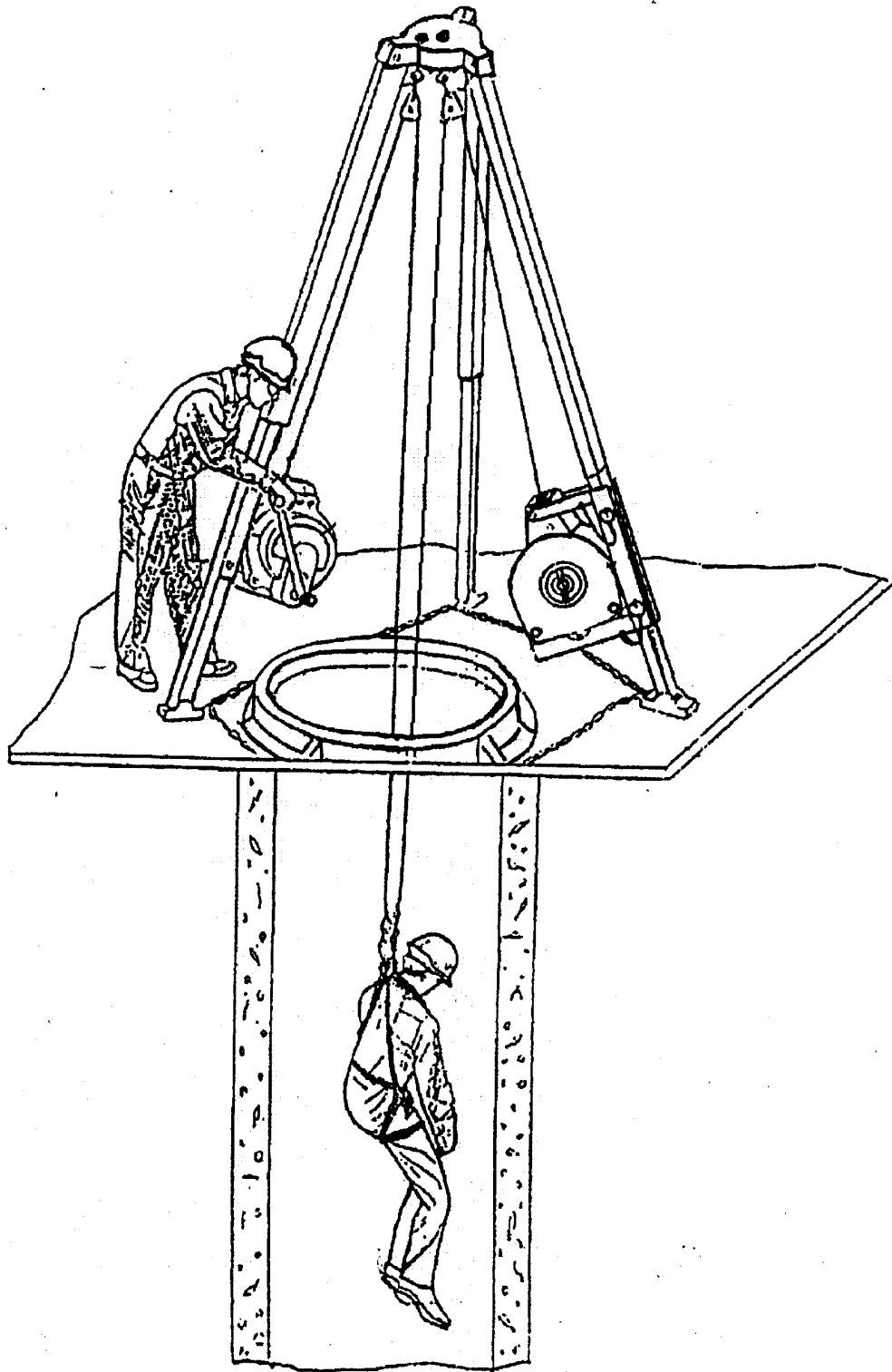

Figure 1. The Tripod System A

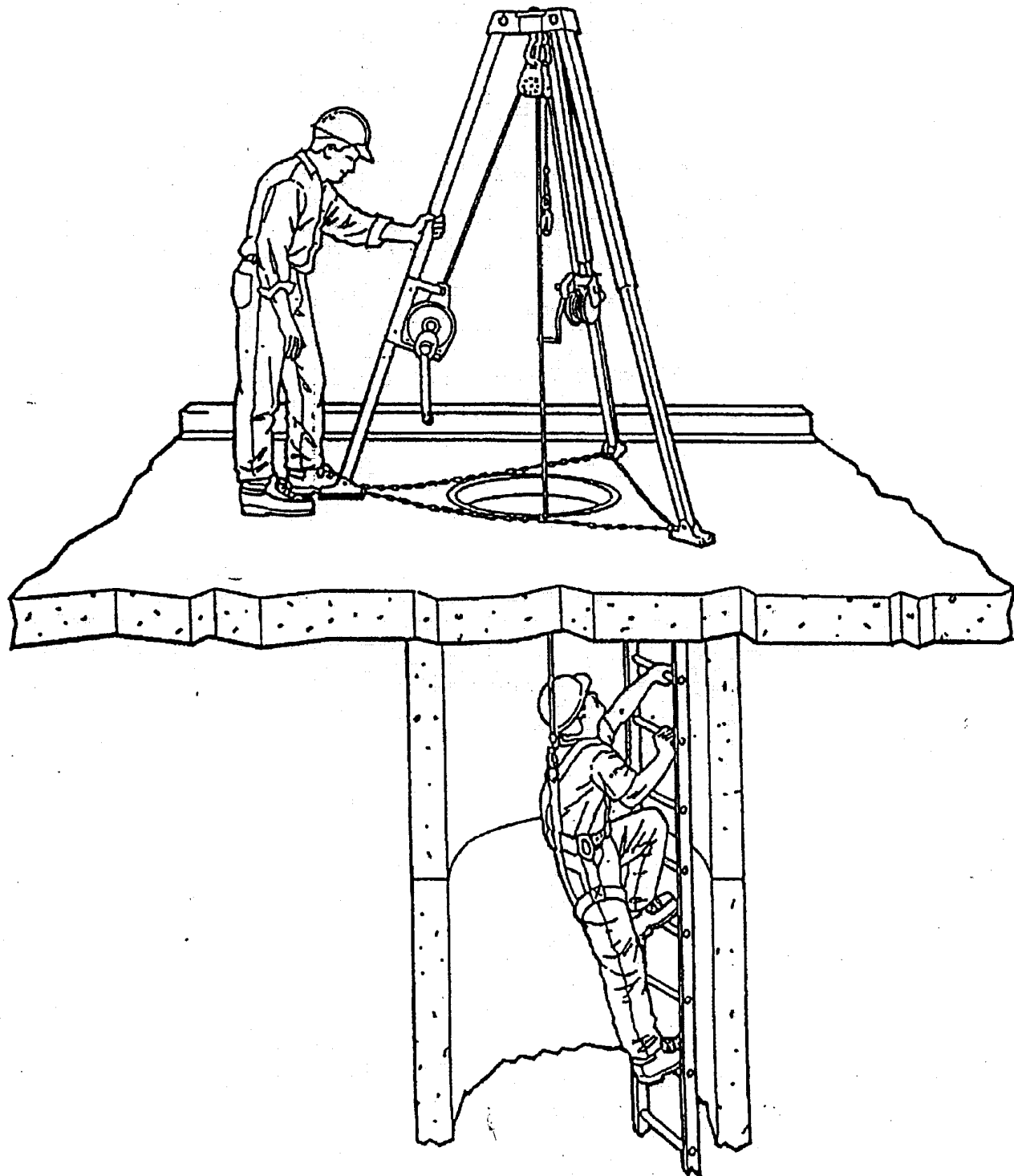

Figure 2. The Tripod System C

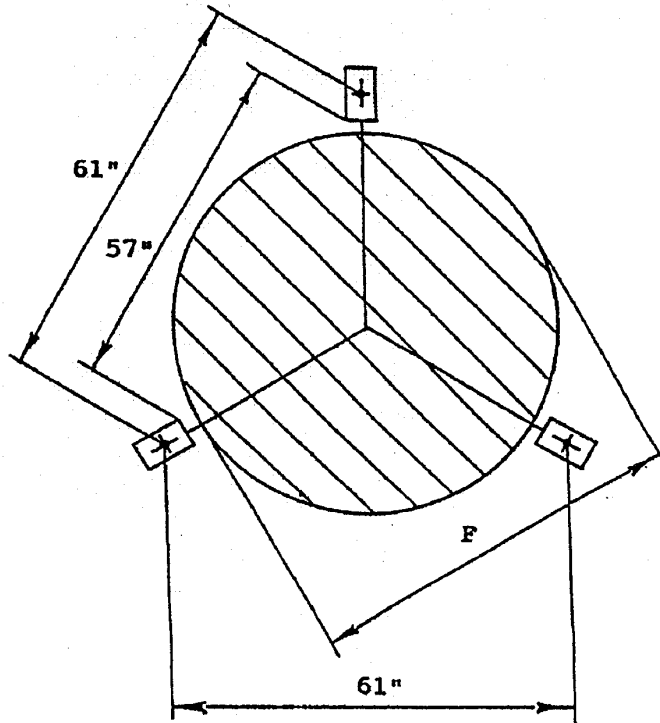
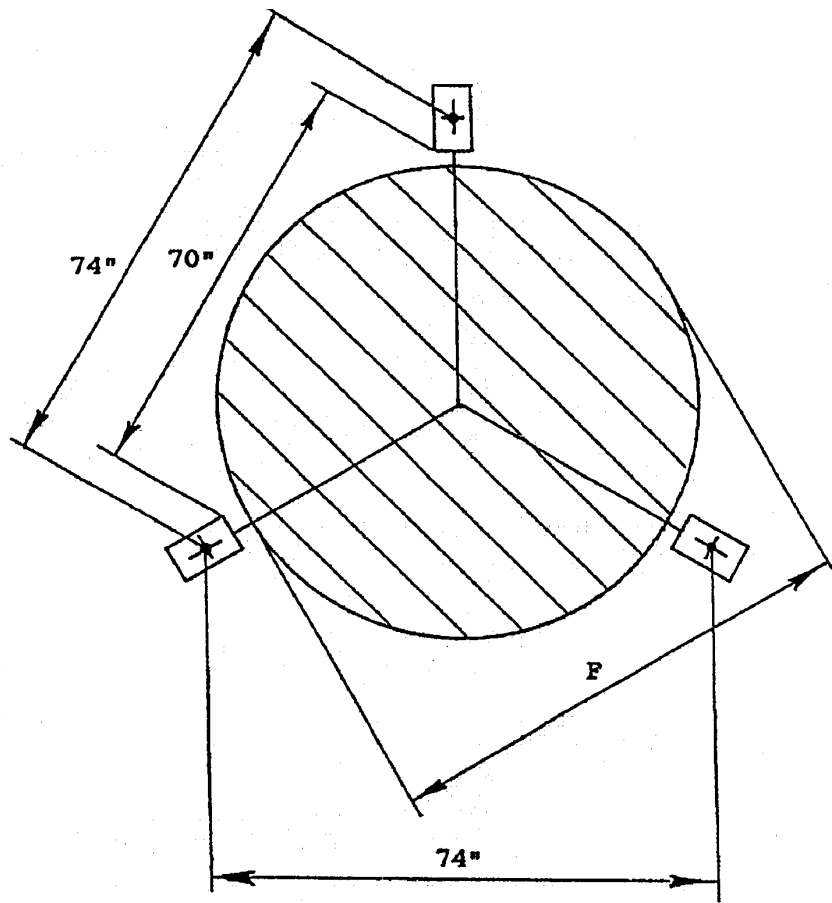

Figure 3. Geometric parameters of the Tripod.
 Upper figure represents P/N 50039, lower figure represents P/N 5003

INSTALLATION PROCEDURES

To assemble System A:

1. Assemble the Tripod (see Tripod Section)
2. Attach the Three-Way Unit (see explanation below)
3. Attach the Personnel Winch (see explanation below)

TRIPOD

For detailed explanation of assembly and disassembly, see Tripod Section (pages 24-25). Before assembling, make sure the Tripod System meets the application requirements.

- Inspect the vicinity around the work area for debris and other material that could cause injuries or interfere with the operation of the system.
- Be sure that the Tripod will be positioned on a hard, stable surface before use. Also, caution should be taken to ensure that all equipment is clear of any electrical hazard and that proper ventilation has been provided in the work area before the worker's descent into the space. When using this equipment, a second worker besides the one attached to the unit must be present as a guide or supervisor.
- The center of the opening corresponds to the center of the cable.
- The diameter of the opening is within the range specified in the technical specifications.

After assembling the Tripod, make sure that it meets the application requirements as described in the technical specifications.

ASSEMBLY PROCEDURES FOR THREE-WAY, AND PERSONNEL WINCH

**The Tripod has an eyebolt attachment.*

Three-Way Rescue and Recovery Unit

1. Attach the Three-Way Rescue and Recovery Unit (Figure 4) to the inside of one of the Tripod legs (1) making sure the unit's bracket is aligned so that both locking pins (6) can be fully pushed in through the leg, firmly securing the unit. Lifting the unit by the winch handle (10) and resting the unit on one's knee will enable the user to easily insert locking pins. Attach a carabiner (2) (narrow end up) to the center eyebolt of the Tripod head. Pull out enough cable from the unit to extend the end past the carabiner. Place the cable through a pulley (3) (pulley halves will slide apart to accommodate cable) and attach the pulley to the carabiner. Make sure that both halves of the pulley are attached to the carabiner and that the cable operates freely in the pulley.

Personnel Winch

Attach the Personnel Winch (Figure 5) to the inside of one of the tripod legs (1) making sure the winch bracket is aligned so that both locking pins (2) can be fully pushed in through the leg, firmly securing the unit. Lifting the unit by the winch handle and resting the unit on one's knee will enable the user to easily insert locking pins. Attach a carabiner (narrow end up) off the center eyebolt (4) of Tripod head (5). Crank out enough cable from the unit to extend the end past the carabiner. Place the cable through a pulley (3) (pulley halves will slide apart to accommodate the cable) and attach the pulley to the carabiner. Make sure that both halves of the pulley are attached to the carabiner and that the cable operates freely in the pulley.

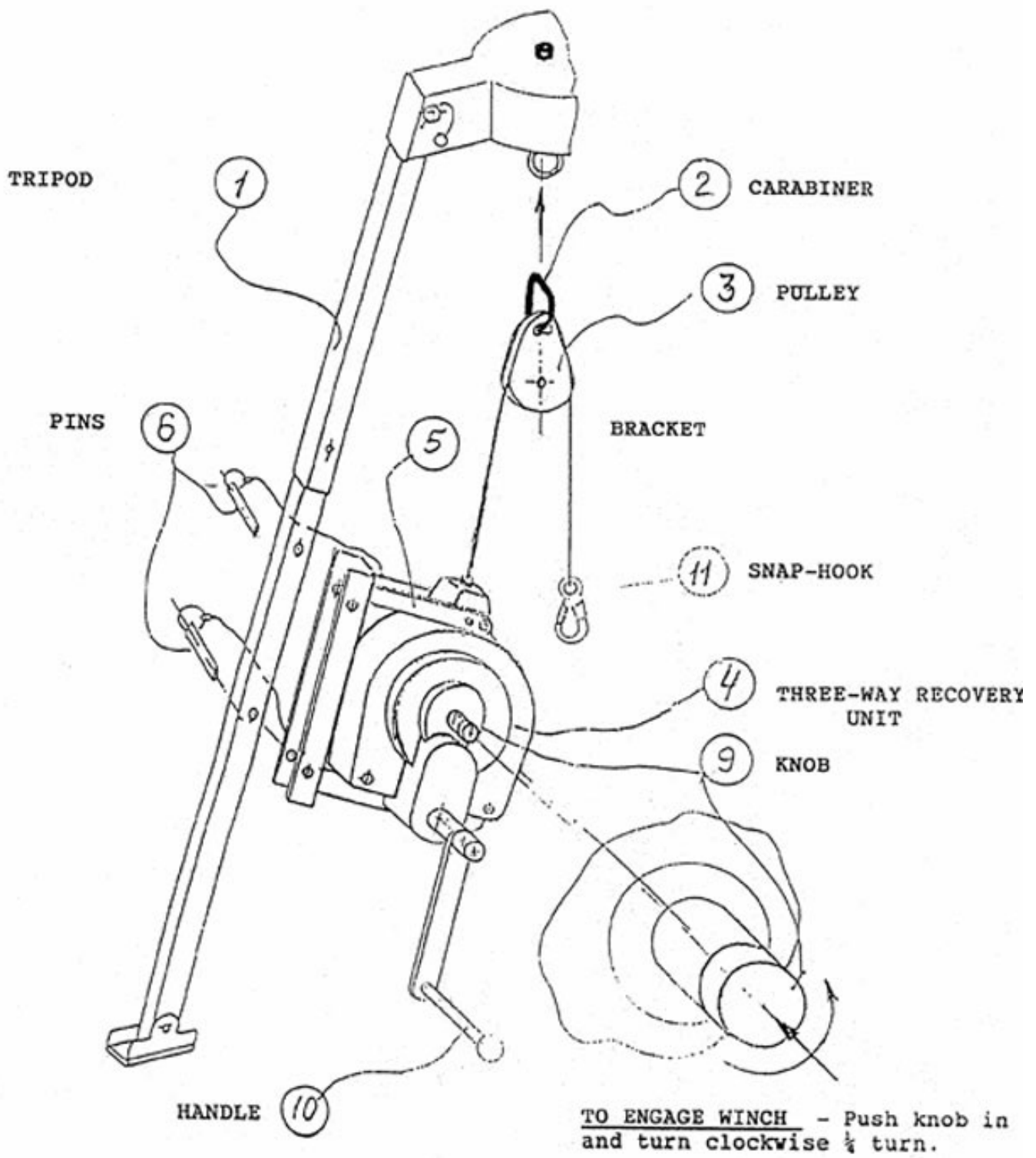

Figure 4. Three-Way Rescue and Recovery Unit - Installation Procedures

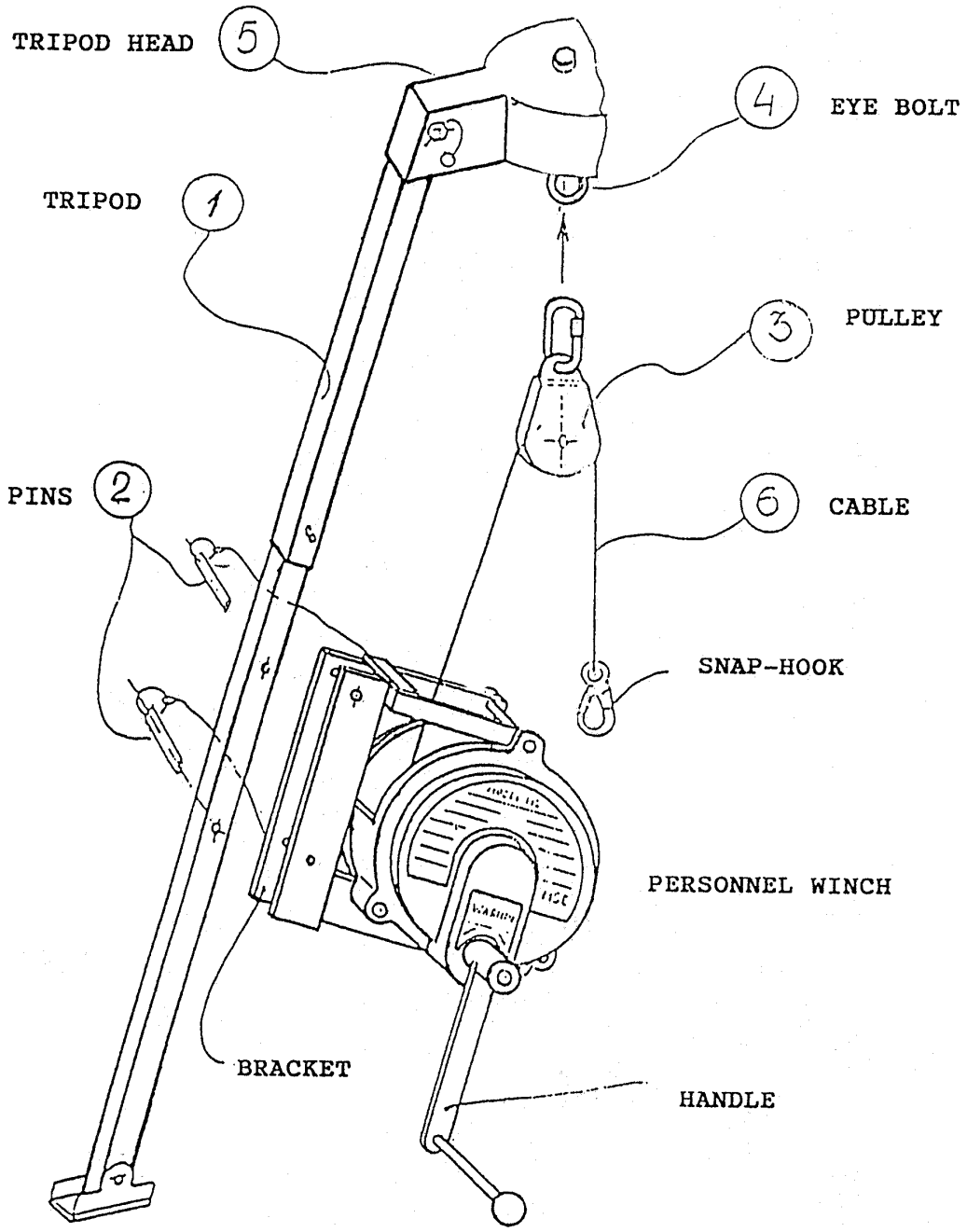

Figure 5. Personnel Winch - Installation Procedures

**If the Tripod has swivel hooks instead of eyebolts, the pulley attaches to the swivel hooks without carabiners.*

INSPECTION PROCEDURES

Three-Way Rescue and Recovery Unit (refer to Figure 4)

1. Check the cables to ensure they move freely and retract correctly. Pull out at least 10 feet of the cable and allow it to retract slowly back into the housing while keeping tension on the cable. If the cable does not pull out smoothly or sticks when retracting, pull the cable out of the housing and allow it to retract slowly under light tension. While the cable is retracting, check for cuts, kinks, broken strands, excessive wear, foreign substances or other damage. The cable should be checked regularly for signs of wear.
2. Test the locking action capability by pulling out approximately 2 feet of cable from the housing, then give the cable a quick, hard, downward tug. The cable should stop and lock.
3. Test the rescue (retrieval) capability.
Unscrew the handle (10) from the mounting bracket (5) and slide it outward. Pull out approximately 2-3 feet of cable from the housing and give it a quick tug to lock it. Maintain downward pressure on the cable. Push the selection, knob (9) in and turn clockwise $\frac{1}{4}$ of a turn to lock the unit into the rescue (retrieval) mode. The rescue capability is now engaged. To raise: **Always first test the raise capability.** Turn the handle in a clockwise direction. Raise approximately 1-2 feet of cable. Then you can lower.
To lower: Maintain downward pressure on the cable and turn handle in a counterclockwise direction.
To change to the fall-arrest mode: a) Take the downward pressure off the cable, push the knob in and turn counterclockwise $\frac{1}{4}$ turn. The knob will "pop" outward. b) secure the Handle (10) to the Mounting Bracket (5) using end screw provided.

Remove from service immediately if any system function or component does not pass this inspection, or whenever subjected to a severe free fall, and return entire device to **BUCKINGHAM MANUFACTURING COMPANY** for inspection repair, and recertification.

Caution: Do NOT force the cable into the housing or through the Tripod pulley. This will cause injury or damage to the rubber stopper, the cable and other equipment.

Personnel Winch

The Personnel Winch (P/N 5010) has a primary brake which holds a load in place when raising or lowering is stopped or when the crank is released. In the event the Personnel Winch would freewheel, an inertia brake system is automatically activated and restricts the payout to a maximum of two feet.

- Visually inspect unit to make sure it is free of dirt and any foreign material. Check snap hook and cable to make sure they are in good condition.
- Check that the quick release pins are in place.
- In order to check the primary brake as well as the function of the winch, attach approximately 20-30 lbs. of load to the hook and turn handle in a clockwise direction. The ratchet action will make a clicking sound and the load has to raise. In order to lower control load, turn handle in a counterclockwise direction. The load must lower. If for any reason the load does not lower or raise or if the handle spins off the shaft, do not use the unit.

- Inspect the snap hooks and connecting hardware to be sure they are not distorted or cracked. Be certain the hook keepers are free of burrs, functioning properly, clean and not bent.

Remove immediately from service if any system, function, component or part does not pass this inspection, or whenever subjected to a severe free fall, and return entire device to **BUCKINGHAM MANUFACTURING COMPANY** for inspection, repair, and recertification.

THREE-WAY RESCUE AND RECOVERY OPERATION (refer to Figure 4)

After the inspection of the whole system, the worker can be attached to the system. If Systems A or B are used for lowering and raising a worker in a confined space without a ladder or other structure, both lifelines must be attached to the D-ring of the harness. Check that the Three-Way Rescue and Recovery Unit is in a retractable fall-arrest mode. This mode is determined by the position of the knob (9) on the handle side of Recovery Unit. It must be outward. The handle (10) should be secured to the mounting bracket (5) using the end screw provided.

Under normal working conditions, the cable is drawn in and out of the Three-Way Rescue and Recovery Unit housing as the worker moves up or down. In this condition, the worker experiences little restraint. The centrifugal brake engages only when there is a fall. The accelerating falling load causes the brake to engage. If the worker activates the unit with a slip fall, but is not injured, and is able to recover without assistance, the Three-Way Rescue and Recovery Unit will reposition itself in a ready position. Once the worker's fall has been arrested, the Three-Way Rescue and Recovery Unit has to be changed from the retractable fall-arrest mode to the rescue (retrieval) mode by the topside worker and the worker raised to safety.

Operate in this situation as follows:

Three-Way Recovery Unit - Rescue (Retrieval) Operation (refer to Figure 4)

1. Unscrew the handle (10) from the mounting bracket (5) and slide it outward.
2. Push the selection knob (9) in and turn it clockwise $\frac{1}{4}$ of a turn to lock the unit into the rescue (retrieval) mode.
3. **Before you make any decision concerning the rescue, remember that even if you need to lower the worker first, you always have to raise him, even if for as short a distance as one foot. To raise a person, rotate the handle clockwise. To lower him, rotate it counterclockwise.**
4. If for any reason the worker becomes wedged while the retrieval is in progress, the topside worker can reverse direction by cranking counterclockwise, thus allowing the worker to be lowered and repositioned before continuing with the retrieval. After the rescue (retrieval) operation is completed, in order to change to fall-arrest mode, the load must be removed from the cable, then:
5. Push the selection knob in and turn it counterclockwise $\frac{1}{4}$ turn. The knob will "pop" outward.
6. Secure the handle (10) to the mounting bracket (5) using end screw provided.

WARNING: During any demonstration or training program, remember that a load or a worker should be attached to the Three-Way Recovery Unit and to the Personnel Winch in order to have a downward pressure on the end of the cable.

Never start the demonstration by lowering. Always start by raising, turning the handle clockwise, after which the direction can be changed by turning the handle counterclockwise. If this is not followed, the handle will become unscrewed from the shaft and the system will become inoperative.

WARNING: This unit is NOT meant to hold or suspend a worker on a regular basis. If suspension or lowering is required, use the Personnel Winch.

Personnel Winch Operation

The Personnel Winch (P/N 5010) is used as a primary work line for the lowering and raising of personnel when there is no ladder or other means of entry into a confined space. When raising and lowering personnel with mechanical devices such as the Personnel Winch, OSHA requires the use of backup fall protection such as the Three-Way Recovery Unit. The Personnel Winch can, however, be used for retrieval should an emergency occur.

If, for any reason, the injured worker becomes wedged during retrieval, the topside worker simply reverses the cranking direction of the Personnel Winch to "down," repositions the injured worker by movement of the cable, and continues on with the rescue/recovery. Casualties are avoided by permitting the rescue squad the opportunity to reposition the injured worker in the confined space without having to enter the contaminated area.

The buddy system (two workers) must always be used with the Three-Way Rescue and Recovery System (Fig.1 and Fig.2). The "topside" worker must not permit an accumulation of slack cable between the worker and the Personnel Winch while the worker is descending. "Slack cables" result from a worker descending a ladder or other means of fixed descent slower than the attached Personnel Winch cable is being advanced.

DISASSEMBLY OF THE SYSTEM

1. Close the cover of the confined space or take any other action in order to prevent the worker from falling.
2. Take the Three-Way Unit pulley off from the Tripod.
3. Allow the cable to fully retract into the unit.
4. Take the Cable of the Personnel Winch from the pulley. Crank the handle of the Personnel Winch clockwise, pulling the cable in. During this procedure, pull the cable by one hand in the direction opposite of the moving cable, thus creating downward pressure. This action will allow the cable to be wound on the drum neatly without loops.
5. Take off the pins that hold the Three-Way Unit on the Tripod leg and remove the unit from the Tripod leg.
6. Remove the pulley of the Personnel Winch from the Tripod.
7. Rotate the handle clockwise, winding the cable on the drum.
8. Remove the pins that hold the unit on the Tripod leg and take the Three-Way Unit off from the tripod leg.
9. Disassemble the Tripod (see Tripod Section).

STORAGE AND MAINTENANCE

A written log of all servicing and inspection dates for this system should be maintained by the company safety officer.

1. Do NOT leave this unit for extended periods of time in an environment where corrosion may take place (i.e. sewage and fertilizer plants). In addition, avoid use in areas that contain high concentrations of ammonia. When used near sea water or other similar environments, more frequent inspection may be necessary to monitor potential corrosive damage. Avoid use with acids, alkaloids, or other caustic chemicals especially at elevated temperatures.
2. Clean the exterior case and retractable cable with water and mild soap / detergent, rinse, and thoroughly air dry. Do NOT use harsh chemicals. Clean labels as required.
3. Never attempt to lubricate, adjust, repair, or modify any recovery system part or component. Repair and re-certification MUST BE performed by **BUCKINGHAM MANUFACTURING COMPANY** annually or more frequently depending on the system's use and operating conditions, or whenever subjected to a severe free fall.

For inspection, repair, and re-certification, and registration of maintenance, return the Three-Way Unit, Personnel Winch and Material Winch along with the manual inspection and maintenance log to **BUCKINGHAM MANUFACTURING COMPANY**
1-11 TRAVIS AVE.
BINGHAMTON, NY 13904

WARNINGS

Before use, read, understand, and follow all instructions and warnings, attached to and/or packed with this unit.

- Inspect before each use. If any part or component shows damage, excessive wear, or does not function properly, the entire system should be removed from service.
- Never use any occupational protective equipment for anything other than its intended use.
- All occupational protective equipment must be inspected and thoroughly tested before each use.
- Do NOT use this system if the total workload exceeds 300 lb.
- All users of this system and its components must be properly trained personnel. Be sure Tripod is positioned on a hard, stable surface before each use.
- Do NOT use the Three-Way Rescue and Recovery Unit if it does not meet the requirements stated earlier in this manual.
- Do NOT use the Personnel Winch if it does not meet the requirements stated earlier in this manual.
- Always use the Tripod as described in the applicable section of the manual.

- Use only locking carabiners, pulley, and locking snap hook supplied with the system.
- Keep all equipment clear of electrical lines and other energized sources. Attach the locking snap hook to only the rear fall-arrest D-ring of a full-body harness. The harness **MUST** meet applicable standards for the intended use.
- Never allow cable to retract uncontrollably.
- Do **NOT** keep cable advanced when a unit is not in use.
- Never clamp off, stand on the cable, or allow the cable to become slack when in use.
- Never use device to support multiple workers (i.e. one system for one worker).
- Never extend cable length by attaching extension lanyard. Use correct cable length for the job.
- Never lengthen or add additional cable to recovery units or winches.
- The buddy system (two workers) must always be used when operating this system.
- The Three-Way Rescue and Recovery Units are **NOT** to be used as a material handling device or for routine lowering and raising of personnel. Only Personnel Winches are to be used for material handling and routine lowering and raising of personnel.
- Never use the Three-Way Recovery Unit for positioning or suspension.
- To ensure compatibility, use only **BUCKINGHAM MANUFACTURING COMPANY** components on this system.
- Do **NOT** use any component of the Three-Way Rescue and Recovery System if the total workload exceeds 300 lb.
- Do **NOT** disconnect the Three-Way Rescue and Recovery System locking snap hook from D-ring any time while worker is in confined space.
- Never attempt to lubricate, adjust, repair, or modify any recovery system part or component. All repairs must be made at
- Do **NOT** use this system if any instructions or warnings are not fully understood.
- Never join two snap hooks together. They are not intended for that use and may twist apart.
- The braking action of the fall arrest device requires a minimum force to engage. Fall arrest function will not operate if footing is on loose or sliding material such as sand or grain.
- **NEVER** leave a weight hanging by the winch while the winch is unattended, as unauthorized persons may attempt to operate the winch, thereby creating an unsafe condition.
- **ALWAYS** keep winch maintained in accordance with this instruction sheet. **REMEMBER** - Worn parts cause unsafe conditions.
- Winch components can be affected by chemicals, salts, and rust and should be examined for unsafe conditions before operating.

- NEVER alter the mechanics of the winch (for example, do not add to the handle length to make easier lifting).
- NEVER use two or more winch units to lift a load that is greater than the load rating of any single unit. A shifting load may place the entire load on one unit, causing sudden failure of equipment, property damage, and serious injury.
- Apply the load evenly. Do not jerk or bounce the load or allow the load to swing. Avoid violent motion and shock loads. This type of operation requires equipment with higher load ratings.
- Each time a load is to be lifted, first test the winch for safe operation by lifting the load a few inches.
- ALWAYS keep hands away from load-bearing cables, ropes, sheaves, drums, and pulleys while operating.
- Remain constantly aware that safe operation is your responsibility.

Components must be inspected regularly by a trained person. Components must be returned to **BUCKINGHAM MANUFACTURING COMPANY** for inspection and re-certification annually or more frequently depending on the system's use and operating conditions, or whenever subjected to a severe free fall.

Employer-instruct employee as to proper use and warnings before any use of equipment.

TECHNICAL SPECIFICATIONS

Three-Way Recovery Unit

The Three-Way Recovery Unit is designed for use in confined spaces such as manholes, tanks, and other confined areas where fall-arrest and retrieval rescue are important.

The Three-Way Recovery Unit provides three functions:

- 1) a braking action if a worker falls (fall-arrest)
- 2) a means for a topside worker to raise another worker (retrieval)
- 3) a means for the topside worker to reverse direction, if, for any reason the worker becomes wedged while retrieval is in progress. The topside worker can reverse direction allowing the worker to be lowered and repositioned before continuing with the retrieval.

Under normal conditions, the cable is drawn in and out of the housing. As long as the speed is moderate, the centrifugal brake is not engaged since the speed of rotation of the internal cable drum is slow. In this condition the worker experiences little restraint while working.

In the event of a fall, however, acceleration of the drum's rotation actuates the braking system. This brings the worker to a gentle stop. The Three-Way Unit permits the confined space worker to be withdrawn by the topside worker without having to enter the potentially dangerous confined space.

Principle of Design	Combination of Personnel Fall Arrest Device, Self-Retracting Lifeline and Retrieval Winch
Cable Length	50 ft.; 65 ft.; 100 ft.
Cable Diameter	3/16" 7 x 19
Type of Cable	Galvanized, Stainless Steel, Synthetic Rope
Breaking Strength	3800 lb. – 4200 lb.
Maximum Working Load	300 lb.
Minimum Working Load	75 lb.
Cable Locking Speed	4-5 ft./sec.
Stopping Distance	2 ft., maximum
Speed	20 ft./min. (approximately) in rescue mode
Gear Ratio	5.5:1
Mechanical Advantage	20:1

Weight	
50 feet (galvanized steel)	44 lb.
50 feet (synthetic rope)	38 lb.
65 feet (galvanized steel)	46 lb.
65 feet (synthetic rope)	38.5 lb.
100 feet (galvanized steel)	62 lb.
100 feet (synthetic rope)	50 lb.

Personnel Winch (P/N 5010)

The Personnel Winch (P/N 5010) is designed to lower or raise personnel in confined spaces with or without the ladder or other means of fixed descent/ascent. The winch can also be used to lower or raise materials.

The Personnel Winch has a primary brake which holds the load in place, when raising/lowering is stopped or when the crank is released. In addition, the Personnel Winch has a secondary brake system. In the case of a freewheel, the centrifugal system is automatically activated.

The PERSONNEL WINCH is furnished with a cable tensioner. The cable tensioner helps keep the cable even and level on the drum to reduce stress and wear.

Maximum Working Load	300 lb.
Minimum Working Load	50 lb.
Lifeline System Strength	3000 lb.
Cable Speed to Engage Brake	4.5 ft./sec
Stopping Distance	24" maximum
Strength Test	300 lb. / 4 ft. Free Fall
Arresting Force	1200 lb. (approximately)
Gear Ratio	5.5 :1
Mechanical Advantage	20 : 1
Retrieval Speed	20 ft./min. (approximately)
Brake System – Fall Arrest	Inertia – Friction Disk
Brake System – Winch	Friction Disk
Cable Length	50 ft, 65 ft., 120 ft.
Weight	-50 feet 35 lb.
	-65 feet 36 lb.
	-120 feet 42 lb.

Tripod P/N 5003 / 50039

The P/N 5003/ 50039 Tripod is a portable, lightweight, high-strength anchor point for confined space and rescue equipment. The major parts of the Tripod are illustrated in Figure 6 and described below.

The cast aluminum head (1) of the Tripod includes either two 5/8" diameter forged steel eyebolts (Figure A) or two locking swivel hooks (Figure B). The lengths of the three aluminum telescoping legs (2) can be adjusted using attached lock pins (6). The proper position of each leg is secured by an automatic hinge lock (4) at the head. The cast aluminum Tripod feet (3) have rubber skid pads to limit movement on slippery surfaces (Figure 8). A safety chain (5) provides secondary backup by preventing the legs from spreading.

The Tripod is available in two modifications: P/N 5003 and P/N 50039.

Technical Specifications

Refer to Figure 3 for illustrations of the geometric parameters of the Tripod and Figures 6 and 9, for explanations of the dimensions listed below.

	5003	50039
Interior headroom height with legs at maximum extension "D"	81"	104"
Interior distance between feet when set up with legs at maximum extension "E"	61"	74"
Maximum hole diameter "F"	44"	60"
Maximum working load	300 lb.	300 lb.
Overall height when set up with legs at maximum extension "C"	88"	111"
Storage length "A"	54"	78"
Outside head diameter	17"	17"
Leg length adjustment increments	2.72"5	2.725"
Weight	41 lb.	47 lb.

Note:

- All lengths are in inches and all weights are in pounds.
- Note: Leg chains will cross over a portion of the opening.
- Tested: Static load with chain - 5400 lb.

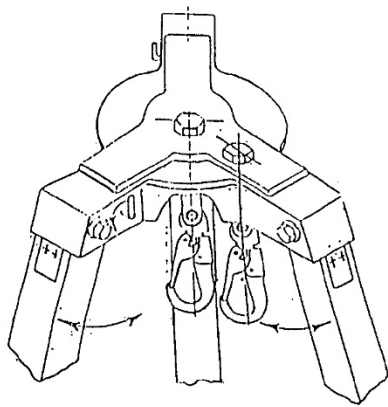

Figure B

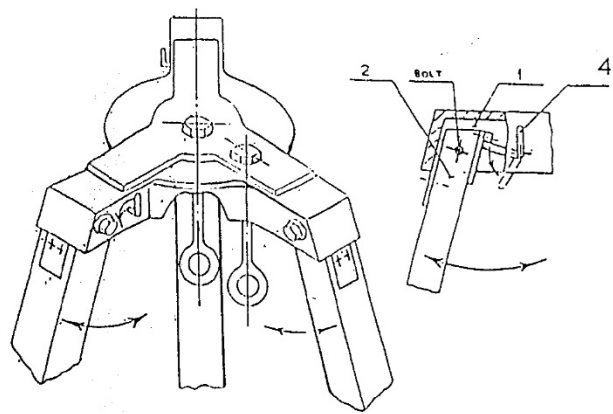

Figure A

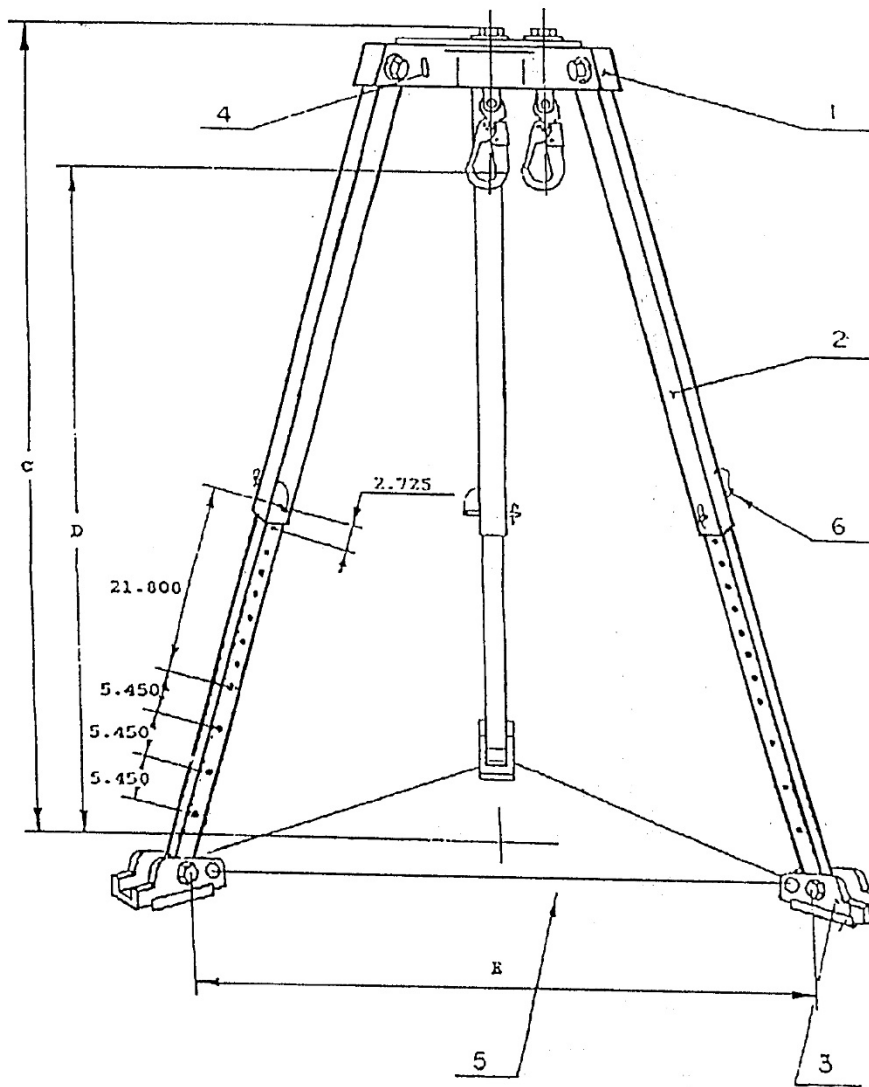

Figure 6. The parts of the Tripod, P/N 5003 / 50039

INSTALLATION INSTRUCTIONS

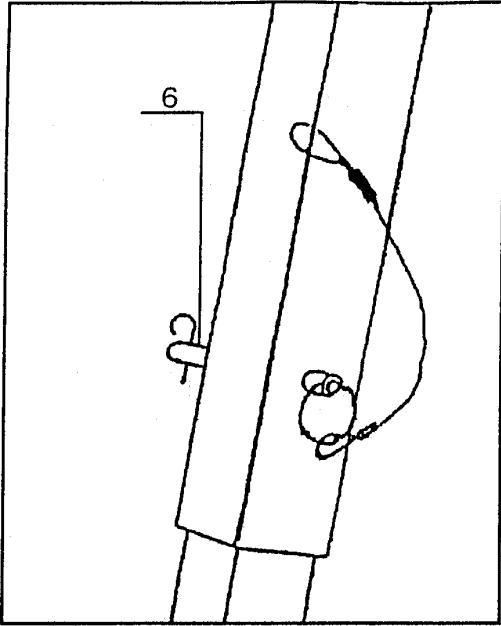

Figure 7. The adjustable telescoping legs with attached lock pins

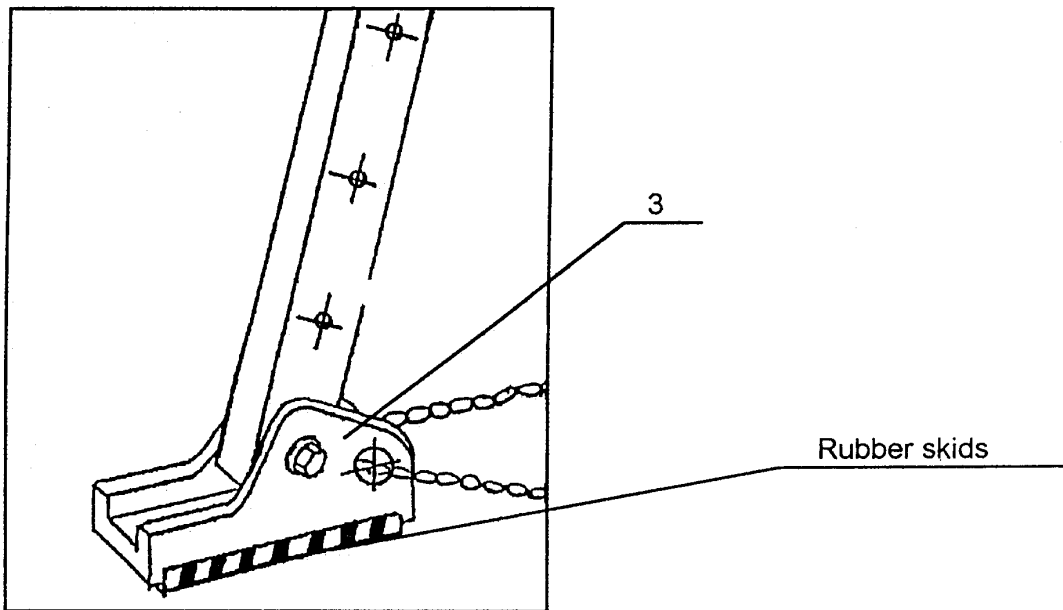

Figure 8. The cast aluminum feet with rubber skid pads and chain

All individuals who may use or be required to use the Tripod **MUST** be instructed on how to use it correctly. They **MUST** read, understand, and follow all instructions and warnings stated on the Tripod or contained in or attached to the Tripod. A review of the proper procedure should be made before each use.

Assembly (refer to Figure 6)

Before using, make sure that the type of Tripod meets the application requirements as described in the technical specifications, that is:

- The center of the opening corresponds to the center of the Tripod.
- The diameter of the opening is within the range specified in the technical specifications.
- The interior height of the Tripod is chosen correctly.

Before assembling, inspect the vicinity around the work area for debris and other material that could cause injuries or interfere with the operation of the system. Be sure that the Tripod is positioned on a hard, stable surface before use, and that the chain (5) is in place and secured. Also, before descent, caution should be taken to ensure that all equipment is clear of any electrical hazard and that proper ventilation has been provided in the work area. There is more than one way to assemble the Tripod. Outlined below is a recommended procedure for assembly.

Recommended Assembly:

1. Lay the contracted Tripod on the floor at a safe distance from the opening.
2. Extend all three legs (2) to full length, securing each with the attached lock pin (6).
3. Lift the Tripod to the vertical position and pull all three legs (2) away from the Tripod center point, making sure that the lock (4) where each leg is hinged to the head (1) is fully engaged.
4. Check to make sure that:
 - All extended legs (2) are secured with lock pins (6).
 - Each leg (2) is set at the furthest point from the center and locked by the hinge lock (4).
 - The chain (5) is in place and adjusted to the right length.
5. Place the Tripod over the confined space opening.
6. Make sure that the Tripod is in a stable position with each foot (3) flat on the floor.
7. The Tripod is now ready for installation of Buckingham Fall Protection equipment.

Disassembly

1. Remove all Buckingham Fall Protection equipment from the Tripod.
2. Remove the Tripod from the confined space opening.
3. After unlocking leg hinges (4) in the Tripod head (1) by turning each pin handle, gradually push each leg (2) to the Tripod center point and embrace all three legs (2). Lower the Tripod, to the ground.
4. Pull the leg lock pins (6) and push the lower leg sections into the upper leg sections. Lock the contracted legs (2) in the storing position with the lock pins (see Figure 6).

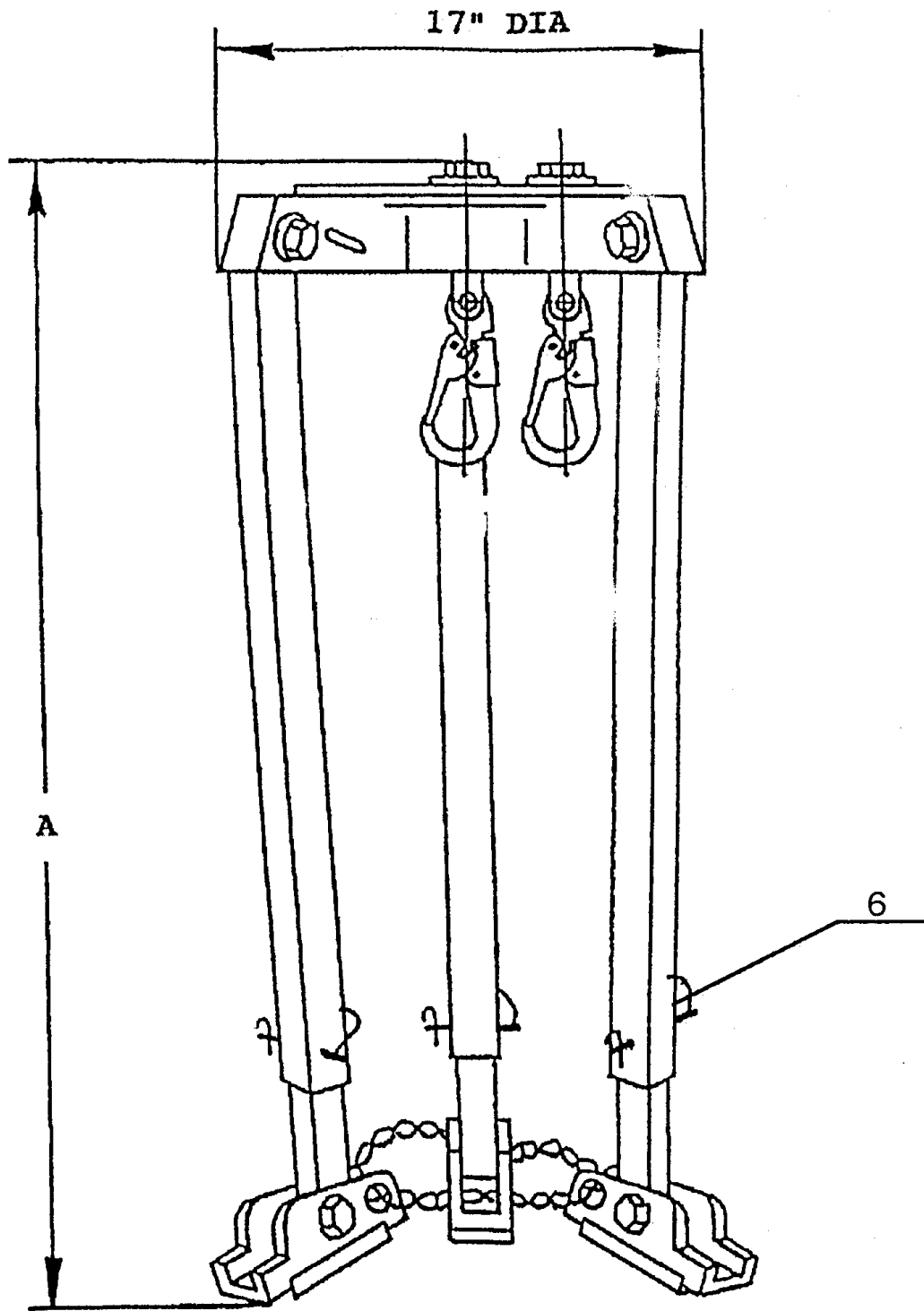

Figure 9. The transport mode of the Tripod

Storage and Maintenance Log for Tripod P/N 5003 / 50039

A written log of all servicing and inspection dates for this device should be maintained by the company safety officer.

1. Always dismount the devices from the Tripod. Store the Tripod in transport mode (Figure 9) in an area free of corrosive elements and excessive heat.
2. DO NOT store this unit in environments corrosive to aluminum. Additionally, avoid use in areas that may contain high concentrations of ammonia. Avoid use with acids, alkaloids, or other caustic chemicals especially at elevated temperatures.
3. Clean exterior of case with water and mild detergent, rinse, and thoroughly air dry. DO NOT use harsh chemicals. Clean labels as required.
4. Never attempt to lubricate, adjust, repair, or modify any part or components. Repair **MUST** be performed by **BUCKINGHAM MANUFACTURING COMPANY**.

WARNINGS

Employer: Instruct employee as to proper use and warnings before use of this equipment.

Read, understand, and follow all instructions and warnings provided with this unit.

For use by properly trained personnel only.

Please consult with your physician prior to using this product. Do not use this product under the influence of drugs or alcohol.

Always use the buddy system (two workers) while operating.

Ensure that the Tripod is positioned on a hard, stable surface before use.

To ensure compatibility, use only Buckingham components.

Use only one device per pulley assembly per eyebolt.

Inspect before use. If any part or component shows damage or excessive wear, or does not function properly, the entire unit should be removed from service.

Never use any occupational protective equipment for anything other than its intended use.

All occupational protective equipment must be inspected and thoroughly tested before each use.

DO NOT use this unit if the total workload exceeds 300 lb.

INSPECTION PROCEDURES

WARNING: NEVER use the Tripod without prior inspection.

1. Inspect the work area for debris and other material that could cause injuries or interfere with the operation of the unit. Be sure that the Tripod is positioned on stable, hard ground before setting it up.
2. The leg chain and all locking pins must again be checked to ensure they are correctly securing equipment. Never use the Tripod without the chain.
3. A competent person, for example a safety director, must schedule regular safety inspection based on amount of use and working conditions.
4. Remove from service immediately if any function, component or part does not pass this inspection, or whenever subjected to a severe free fall.
5. Never use the Tripod in conjunction with safety devices not manufactured by BUCKINGHAM MANUFACTURING COMPANY or designed specifically for use with this Tripod.

WARRANTY

BUCKINGHAM MANUFACTURING COMPANY warrants mechanical devices against factory defects in workmanship and materials for a period of one year from the date of shipment.

BUCKINGHAM MANUFACTURING COMPANY reserves the right to have any defective item returned to its plant for inspection before making a repair or replacement.

This warranty does not cover damage resulting from abuse, damage in transit, or other damage beyond the control of BUCKINGHAM MANUFACTURING COMPANY.

Inspection Date	Inspection Items Noted	Corrective Action Taken	Maintenance Performed
Approved by: _____			
Approved by: _____			
Approved by: _____			
Approved by: _____			
Approved by: _____			
Approved by: _____			
Approved by: _____			
Approved by: _____			
Approved by: _____			

Information contained in these written instructions supersedes all other information (written, audio, video etc.) produced by Buckingham Mfg. prior to the revision date of this document.

STATEMENT of OBSOLESCENCE:

Precise “useful life expectancy” or “shelf life” for this product is not specified, as the degree of use, conditions of use, and the degree of care and storage determines useful life. All users maintain responsibility to select proper equipment for the job, be properly trained in its use, and ensure all personnel support equipment passes inspection before each use. Upon evidence of defects, damage or deterioration, all equipment shall be removed from service immediately and tagged or marked as unusable or destroyed. Additionally, all equipment shall be inspected on a regular basis not to exceed one year by a Competent Person, as defined by

OSHA/ANSI, to verify that the equipment is safe for use. In the event of any question or concern regarding the condition of such equipment, users shall remove the equipment from service for further inspection. All users must comply with OSHA/ANSI/ASTM standards prior to and in using such equipment. For more information regarding safe and appropriate use of equipment, please contact Buckingham Manufacturing at 1-800-937-2825.

INTERNATIONAL USERS:

Notwithstanding the above, please know that certain international jurisdictions require manufacturers of equipment to provide customers with a maximum useful lifespan (sometimes referred to as a “Statement of Obsolescence”). To the extent required, Buckingham personal protective equipment manufactured from synthetic fiber materials including but not limited to items such as webbing and/or rope are subject to a maximum useful lifespan of ten (10) years from the date of manufacture. As stated above proper usage, storage, maintenance, and care impacts the useful lifespan of equipment. Extreme circumstances may require that product must be retired after only one use. This statement is made in conformance and compliance with BS EN 365:2004. International users must ensure that product inspections are completed by Competent Persons as defined by international standards including but not limited to British Standard (“BS”). If equipment fails any inspections, it must be immediately withdrawn from service and destroyed. For more information regarding safe and appropriate use of equipment, please contact Buckingham Manufacturing at 1-800-937-2825.

OUR GUARANTEE:

We guarantee the equipment we manufacture to be free from defects in material and workmanship. We will repair any equipment deemed to be defective which is returned to us by the original purchaser. However, this guarantee is void if any product is changed or altered in any way, or if the product is used in a manner other than for which it is intended. This express guarantee supersedes all other expressed or implied guarantees, obligations or liabilities. There are no implied warranties of merchantability or fitness for a particular purpose and as such, all implied warranties are specifically disclaimed.

LIMITATION ON LIABILITY:

In no event will Buckingham or buyer be liable to the other for lost revenues, lost profits or any other indirect, consequential, special or punitive losses or damages, however caused, whether in action for breach of contract, strict liability, tort, or otherwise, even if advised of the possibility of such losses or damages. In no event will Buckingham’s liability exceed the total amount paid by the buyer to Buckingham for the product or equipment giving rise to such claim(s).

Please see other terms and conditions relating to this product at <https://buckinghammfg.com/terms-conditions/>

REGISTRATION:

Before use of the product, ensure to register and confirm the product at www.buckinghammfg.com/register.

BUCKINGHAM MFG.
BINGHAMTON, NY
(1-800-937-2825)
www.buckinghammfg.com