

# BUCKINGHAM MFG.

## INSTRUCTIONS / WARNINGS

### P/N 25 Series

#### 'Tear-Away' Chain Saw Lanyard

Warning: Do not use this product if you cannot understand and follow the instructions and warnings that come with it and complete all necessary functions.

Please consult with your physician prior to using this product. Do not use this product under the influence of drugs or alcohol.

### INSTRUCTIONS

1. Attach the 'Saddle End' to the tree saddle.
2. Using a hitch, attach the 3 1/2" diameter loop to the handle of the chain saw as shown in Illustrations 'A' and 'B' to the right.
3. The optional 1 3/4" diameter steel ring on the lanyard may be used for connection to the tree saddle accessory snap or carabiner when transporting the saw.
4. See illustration below for additional details.

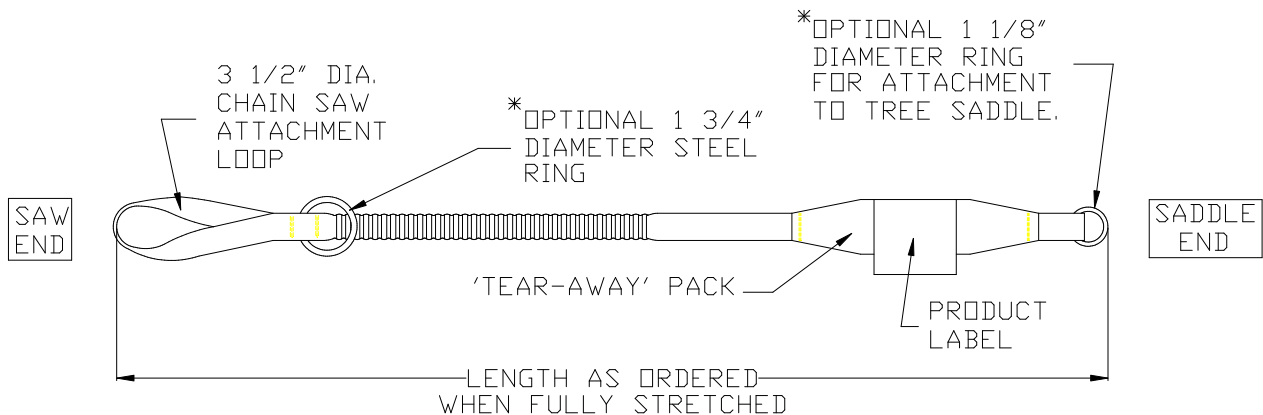
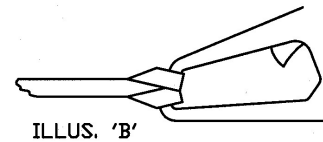
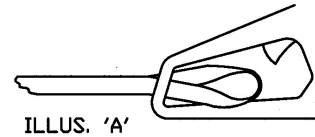

REFER TO 'TEAR-AWAY' CHAIN SAW MATRIX (OVER) FOR ADDITIONAL OPTIONS

### WARNINGS

- ***THIS PRODUCT IS NOT TO BE USED FOR FALL RESTRAINT OR FALL ARREST.***
- For proper tear-away function, this product must not be used with a chain saw weighing more than 15 lbs. (fully fueled).
- Dropping your saw is not recommended as it will cause deployment of the unit.
- Remove unit from service, destroy and discard if chain saw is dropped.

**NOTE:** Ensure proper fit / size of product before use. This product can not be returned unless it is in new / unused condition.

(OVER)

## Tearaway Chainsaw Lanyard Matrix

Model # Prefix	Chainsaw End	Saddle End	Options
<b>25G</b> = 1" High Vis. Green (PN 252038)	<b>1</b> = 3 1/2" Dia. Nylon Loop w/ Twist Half Hitch To Saw Handle	<b>1</b> = 3 1/2" Dia. Nylon Loop (Buckle option (B or C) must be used)	<b>A</b> = 1 3/4" Diameter Steel Ring to Suspend
	<b>3</b> = #2 Bronze Boat Snap	<b>2</b> = 1 1/8" Steel Ring	<b>B</b> = Quick Disconnect Buckle Located on Saw End
	<b>6</b> = #3 Bronze Swivel Snap	<b>3</b> = #2 Bronze Boat Snap	<b>C</b> = Quick Disconnect Buckle Located on Saddle End
	<b>7</b> = Brass Dog Snap 3/4" Swivel Eye (225B) {220231}	<b>4</b> = 3/4" Diameter Loop	
		<b>5</b> = #125 Snap	
		<b>6</b> = #3 Bronze Swivel Snap	
		<b>7</b> = Brass Dog Snap 3/4" Swivel Eye (225B) {220231}	

## **STATEMENT of OBSOLESCENCE:**

Precise “useful life expectancy” or “shelf life” for this product is not specified, as the degree of use, conditions of use, and the degree of care and storage determines useful life. All users maintain responsibility to select proper equipment for the job, be properly trained in its use, and ensure all personnel support equipment passes inspection before each use. Upon evidence of defects, damage or deterioration, all equipment shall be removed from service immediately and tagged or marked as unusable or destroyed. Additionally, all equipment shall be inspected on a regular basis not to exceed one year by a Competent Person, as defined by OSHA/ANSI, to verify that the equipment is safe for use. In the event of any question or concern regarding the condition of such equipment, users shall remove the equipment from service for further inspection. All users must comply with OSHA/ANSI/ASTM standards prior to and in using such equipment. For more information regarding safe and appropriate use of equipment, please contact Buckingham Manufacturing at 1-800-937-2825.

## **INTERNATIONAL USERS:**

Notwithstanding the above, please know that certain international jurisdictions require manufacturers of equipment to provide customers with a maximum useful lifespan (sometimes referred to as a “Statement of Obsolescence”). To the extent required, Buckingham personal protective equipment manufactured from synthetic fiber materials including but not limited to items such as webbing and/or rope are subject to a maximum useful lifespan of ten (10) years from the date of manufacture. As stated above proper usage, storage, maintenance, and care impacts the useful lifespan of equipment. Extreme circumstances may require that product must be retired after only one use. This statement is made in conformance and compliance with BS EN 365:2004. International users must ensure that product inspections are completed by Competent Persons as defined by international standards including but not limited to British Standard (“BS”). If equipment fails any inspections, it must be immediately withdrawn from service and destroyed. For more information regarding safe and appropriate use of equipment, please contact Buckingham Manufacturing at 1-800-937-2825.

## **OUR GUARANTEE:**

We guarantee the equipment we manufacture to be free from defects in material and workmanship. We will repair any equipment deemed to be defective which is returned to us by the original purchaser. However, this guarantee is void if any product is changed or altered in any way, or if the product is used in a manner other than for which it is intended. This express guarantee supersedes all other expressed or implied guarantees, obligations or liabilities. THERE ARE NO IMPLIED WARRANTIES OF MERCHANTABILITY OR FITNESS FOR A PARTICULAR PURPOSE AND AS SUCH, ALL IMPLIED WARRANTIES ARE SPECIFICALLY DISCLAIMED.

## **LIMITATION ON LIABILITY:**

IN NO EVENT WILL BUCKINGHAM OR BUYER BE LIABLE TO THE OTHER FOR LOST REVENUES, LOST PROFITS OR ANY OTHER INDIRECT, CONSEQUENTIAL, SPECIAL OR PUNITIVE LOSSES OR DAMAGES, HOWEVER CAUSED, WHETHER IN ACTION FOR BREACH OF CONTRACT, STRICT LIABILITY, TORT, OR OTHERWISE, EVEN IF ADVISED OF THE POSSIBILITY OF SUCH LOSSES OR DAMAGES. IN NO EVENT WILL BUCKINGHAM’S LIABILITY EXCEED THE TOTAL AMOUNT PAID BY BUYER TO BUCKINGHAM FOR THE PRODUCT OR EQUIPMENT GIVING RISE TO SUCH CLAIM(S).

PLEASE SEE OTHER TERMS AND CONDITIONS RELATING TO THIS PRODUCT AT  
<https://buckinghammfg.com/terms-conditions/>

## **REGISTRATION:**

Before use of the product, ensure to register and confirm the product at [www.buckinghammfg.com/register](http://www.buckinghammfg.com/register).

**BUCKINGHAM MFG.**  
BINGHAMTON, NY  
(1-800-937-2825)  
[www.buckinghammfg.com](http://www.buckinghammfg.com)