

BUCKINGHAM MANUFACTURING

BODY BELT SIZING - MAINTENANCE - IN USE CARE

Buckingham Body Belt Sizing Chart

1. Determine your "Y" measurement (see method & diagram below).
2. Determine what class your Body Belt is in using the chart below (ex. A 2000M belt is in Class 1).
3. Find your "Y" measurement, then go across to the column that has your Belt Class. This is the D-size you need to order. (ex. Your "Y" measurement is 24" and you want a Class 1 (2000M) Body Belt, you would order a size 26).

Class 1	2000M, 2000EM*, 20003M, 20005M, 20006M, 2100M, 20182M, 2107M, 1988M, 1958, 1962M, 19655M, 1902, 1993F, 1994F, 1994FR, 4200, 20192M, 20193M, 20122M, 4300
Class 2	2012M, 2013M, 2014M*, 2015M*, 2017M*, 2018M, 20181M, 2019M, 20191M

*Made in sizes 20-30 only

Y Measurement	SIZE TO ORDER	
	Class 1	Class 2
16	18	20
17	19	21
18	20	22
19	21	23
20	22	24
21	23	25
22	24	26
23	25	27
24	26	28
25	27	29
26	28	30
27	29	31
28	30	32
29	31	33
30	32	34
31	33	35
32	34	36
33	35	37
34 (MAX)	36	38

Green Numbers = Standard Sizes
Red Numbers = Non Standard Sizes

X - Distance from waist to top of hip bone where body belt is typically worn.
Y - Measurement is from front of hip bone, around the back and to the front of the other hip bone (Typically from seam to seam of pants).

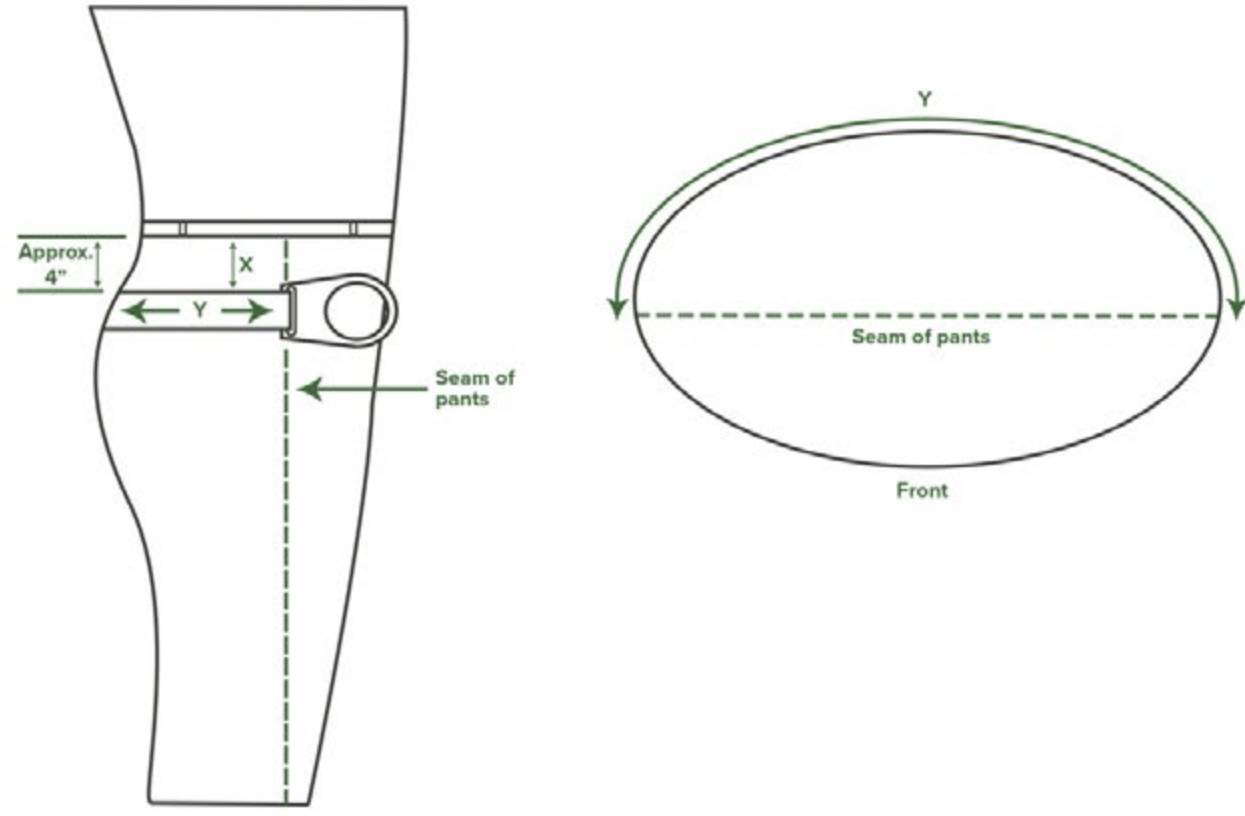

Note: To ensure proper body belt sizing, always take your Dee (Y) measurement using a tape or sizing belt. Never rely on your current body belt Dee size.

Types of Body Belts

- **Full Float**
Full float body belt allows the d-rings to shift approximately 4" and the waist is stationary
- **Semi Float**
On Semi float body belts the d-rings are stationary and the waist strap shifts within the back pad

Sizing Belt

[Watch the video at BuckinghamMFG.com/videos](https://www.buckinghammfg.com/videos)

Buckingham offers a sizing belt that is designed to provide the user with an exact hip to hip measurement to ensure an accurate dee reading.

For proper belt size:

- Padded Belts:** add 2 inches
 - Lightweight Dri-lex belts:** add 4 inches
- Measures sizes 18 to 30



Model 6087

BODY BELT SIZING

BODY BELT INSPECTION

Body Belt Inspection

ALWAYS LOOK TO ENSURE YOU ARE ATTACHED TO THE D-RING - NEVER ASSUME

1. **Tongue Buckle**
 - Check for cracks and/or corrosion
 - Never file tongue hook
 - Check for loose stitching and loose or worn rivets
2. **Tool Loops**
 - ASTM prohibits tools and accessories in center of back
 - Check for cuts, tears or loose stitching on loops
 - Inspect for worn material
3. **Suspender Dee**
 - Check for secure rivet
 - Only rated to 25 lbs. used for belt support
 - NOT MAN RATED
4. **Waist Strap**
 - ASTM requires no holes in last 4" of billet
 - Inspect for worn material, loose stitching, broken threads & burns
 - Check for loose grommets or elongated holes on waist strap
 - Check for loose or worn rivets
5. **Knife Accessory Snap**
 - Working spring
 - Secure & not broken
6. **Glove Bag Ring**
 - Secure & not broken
7. **Pouch Tab**
 - OSHA requires the pouch attachment hole measure 3" from back of circle
 - Designed so user does not connect to tools instead of dee
8. **Tape Thong**
 - Inspect for worn material
9. **D-Ring**
 - Inspect for cracks, nicks, distortion, or corrosion of hardware

IMMEDIATELY REMOVE THE BELT FROM SERVICE IF ANY OF THESE CONDITIONS EXIST

NEVER

- Modify or punch a hole in a support component of the body belt
- Use a body belt containing all leather load bearing components
- Disconnect waist strap and rely on gut strap or suspenders (Suspenders and gut straps are rated to a maximum of 25 lbs.)
- Use accessory ring, snap or suspender rings for work positioning

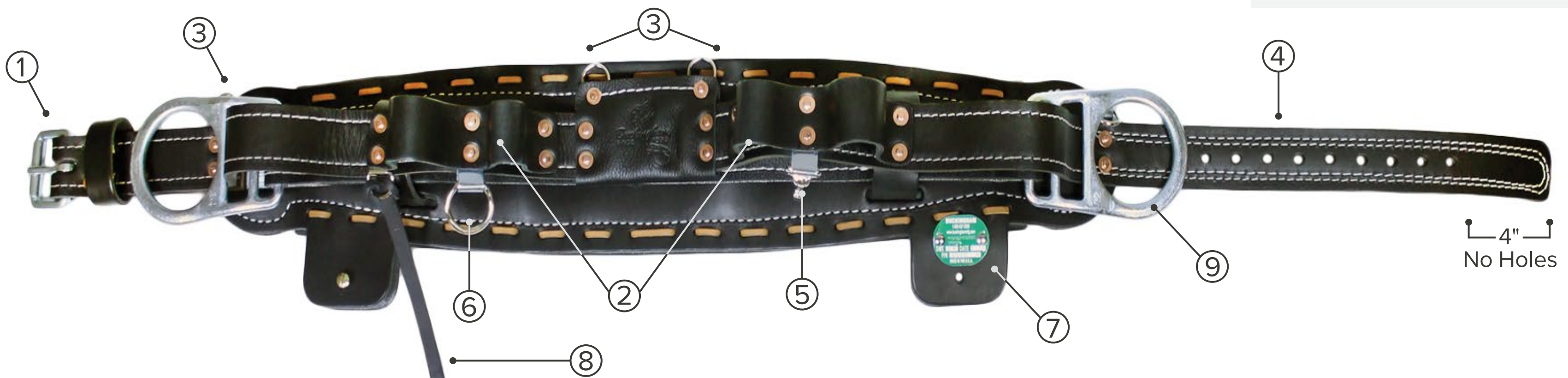

4" No Holes

Body Belt Styles

All 4-D Body Belts are Patented.



- Model 20192CM Adjustable Short Back Belt™**
(Patent Pending)
- The only adjustable body belt on the market.
 - Now in S, M, L, & X.



- Model 20122EM-BH Heritage In-Line 4 D-Ring Belt**
- 4 In-Line D-rings



- Model 20192M Leather Mobility™ Belt**
- 4 Stacked D-rings



- Model 20182M Dri-lex Mobility™ Belt**
- 4 Stacked D-rings

Accessories



- Model 47333G9R5S Buck Big Mouth Bag™**
- Extended wide mouth (15 1/2" x 22") makes storing PPE, gear, tools, and other items easier & faster
 - No more struggling to get equipment into your bag & no more fighting to get it closed!



- Model 2404G Gated Handline Carrier**
- Gate prevents handline or tools from inadvertently falling off. Hook can also be locked behind gate, increasing the amount of force that is needed to straighten it to 35 lbs.



- Model 9M8-8 Buck LeverJust™**
- Lightweight Adjustable Positioning Lanyard (APL) designed to allow one-handed adjustments without removing weight from the lanyard thanks to the new LeverGrab™



- Model 2404 BuckTender™**
- Designed to keep excess slack from the tail of the BuckAdjuster™ secondary lanyard or wood pole fall restriction device out of the way while climbing & working

Government & Consensus Standards

- All Buckingham body belts meet applicable sections of OSHA regulations, 1926.954 and 1910.265, and the ASTM F887 standard
- Belts are designed to provide the user with maximum, safety and necessary belt accessories
- Body belts are designed for work positioning and not intended for fall arrest

