

BUCKINGHAM MFG.

INSTRUCTIONS / WARNINGS

BUCKINGHAM MODEL 5203 SERIES HARNESS BEAMS

Warning: Do not use this product if you cannot understand and follow the instructions and warnings that come with it and complete all necessary functions.

The harness beam is designed to be used by electric utilities and training facilities for the training of apprentice **linemen**. It is designed to fit over the top of the utility pole and to be secured in place by the eight leveling footpads / bolts. Additionally, the harness beam provides a support structure for a fall arrest system including, a rated anchor point for a retractable lifeline in compliance with regulatory standards. The snaphook of the retractable lifeline is to be connected to the dorsal attachment of a fall arrest harness being worn by the user. If the user were to experience a gaff “cut out”, the retractable lifeline would engage and arrest the fall, preventing the user from falling to the ground. The device allows rotation of a lifeline 360° around the utility pole with little effort and is easily installed and removed from a utility pole without extensive setup.

Selection of products should be such that they aid the worker in the performance of his job and particular work situation. Therefore, be certain this equipment is suitable for the intended use and work environment. It should only be used as personal protection equipment. If suitability for intended use is questionable, always consult your Supervisor, Safety Director or contact Buckingham Mfg. at (607) 773-2400 or 1-800-937-2825.

INSTALLATION GUIDELINES

1. This unit will accommodate 9.5” diameter poles. Larger diameter poles must be shaved to meet this requirement. NOTE: A 45 ft. class 3 pole should accommodate the 5203 Harness Beam without shaving the pole top. Buckingham Manufacturing recommends using the 5203-12 Harness Beam for pole diameters larger than 9.5” and up to 12”.
2. The eight threaded anchor pins (4 top, 4 bottom) must be backed out such that the unit will slide over the pole top.
3. The Harness Beams weigh approximately 160 lbs. Rigging, winch lines, booms and all lifting equipment must have appropriate capacities.
4. To attach the Harness Beam to the pole top:
 - Connect the winch line to the Harness Beam using the lift eye provided at the top of the unit. NOTE: Do not attempt to install this unit on the pole with the retractable lifeline already attached to the arm.
 - Lower the Harness Beam onto the top of the pole until it bottoms out.
 - Level the Harness Beam. Set a level on the flat area just below the arm (level sitting left to right as installer is facing unit) and check. Level in a second direction with the level located 90° from its first position. When level, tighten the eight (8) anchor pins. Move the level to it’s original position and recheck. If not level, the installer must loosen anchor pins, reposition the unit to level and retighten the anchor pins.

5. Connect the locking carabiner attached to the anchor mounting bracket of the Retractable Lifeline to the attachment hole of the Harness Beam arm. Also, tie a tag line to the Retractable Lifeline snap hook and pull the lifeline down as needed from ground level and to control the speed of retraction upward into the housing.
6. Contact Buckingham Mfg. Co. at (607) 773 - 2400 or 1-800-937-2825 should you have questions relative to these installation guidelines or the product.

Inspection Procedure

1. Inspect the complete Harness Beam assembly frequently and at regular intervals.
2. Inspection should include but not be limited to those areas shown in the illustration below.
3. The entire unit should be inspected for:
 - a. visible cracking
 - b. corrosion
 - c. excessive wear
 - d. distortion
 - e. any other visible damage
4. Check the six cap screws on the top of the unit (surrounding the eye bolt) for tightness.
5. Check arms for ease of movement. Arms should rotate around the center post smoothly and easily with no binding.
6. Check arms for excessive vertical movement. Movement in this direction could mean worn bearings or insufficient tightness of the cap screws.
7. All welds must be inspected for visible cracks or breaks.
8. Ensure all anchor pins and leveling footpads turn smoothly and are not rusted. If the Harness Beam is installed on the pole, check that all anchor pins and leveling footpads are present and have not loosened. If any of the anchor pins have loosened, retighten the loose pin(s) and recheck that the Harness Beam is level. Lubricate anchor pins and leveling footpads as often as required to maintain smooth operation (no binding) with light weight lubricant such as WD-40®.

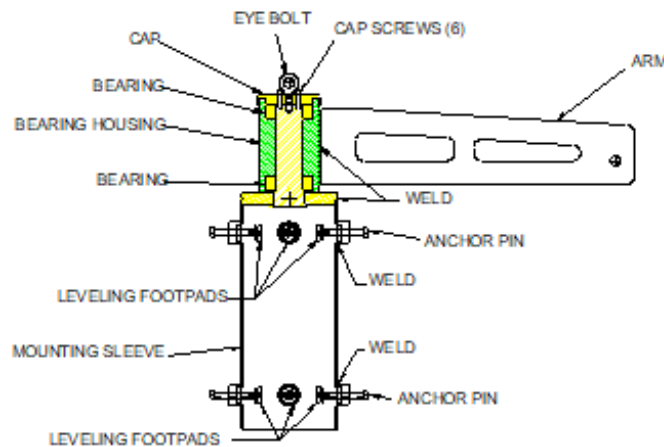

MODEL # 5203

WARNINGS

- Manufacturer's instructions shall be provided to the user of this product. If additional copy is needed, contact Buckingham Mfg. Co.
- Completely read, understand, and follow all instructions, warnings, and guidelines pertaining to this and all associated equipment before use. Failure to do so could result in your serious injury or death.
- Employer - instruct your employees as to proper use, warnings and cautions before use of this equipment.
- Use the Harness Beam only with qualified trained supervision. Do not use without proper training.
- Before use of the equipment, consideration should be given as to how any necessary rescue could be safely achieved.
- Per OSHA 1926.502 (d) (20): The employer shall provide for prompt rescue of employees in the event of a fall or shall assure that employees are able to rescue themselves.
- In the event of a fall, the employer must have a rescue plan and the means to implement it.
- Thoroughly inspect the Harness Beam and all associated equipment prior to each use.
- DO NOT install the Harness Beam on or near a utility pole that contains live power wires.
- Never install the Harness Beam on a cracked or damaged utility pole.
- The Harness Beam will function best on a utility pole that is plum.
- This equipment must only be used for personal use only, not for hoisting.
- Only Buckingham Mfg. Co. or those people authorized in writing by Buckingham Mfg. Co. may make repairs / modifications to this equipment.
- Never work without independent fall arrest protection if there is danger of a fall.
- Attach only compatibly sized snap hook onto rear fall arrest D-ring on harness and fall arrest anchor point. In the absence of a compatibly sized connector, use a locking type connector designed for the intended application.
- Always visually check that each snap hook / carabiner freely engages D-ring or anchor point and keeper / gate is completely closed with each use. **Never** rely solely on the feel or sound of a snap hook / carabiner engaging.
- Make sure each snap hook / carabiner is positioned so that its keeper / gate is **never** load bearing.
- Ensure there is no pressure on the snap hook locking mechanism sufficient to depress it as this will, due to its length, render it incompatible with currently designed rings and make it very susceptible to rollout.
- Never disable locking keeper / gate on snap hook / carabiner, punch holes in or alter a connecting device in any way.
- Always keep anchor point above rear fall arrest attachment. Never climb above the anchor point of the harness Beam.
- Never attach more than one Retractable Lifeline or user to an attachment hole of a Harness Beam arm.
- Ensure the line of the Retractable Lifeline attached to the harness beam does not become tangled or hung up on the pole during maneuvering about the pole while climbing or performing other operations.
- Product covered under these instructions / warnings should not be resold / redistributed or re-used after use by original user.

STATEMENT of OBSOLESCENCE:

Precise “useful life expectancy” or “shelf life” for this product is not specified, as the degree of use, conditions of use, and the degree of care and storage determines useful life. All users maintain responsibility to select proper equipment for the job, be properly trained in its use, and ensure all personnel support equipment passes inspection before each use. Upon evidence of defects, damage or deterioration, all equipment shall be removed from service immediately and tagged or marked as unusable or destroyed. Additionally, all equipment shall be inspected on a regular basis not to exceed one year by a Competent Person, as defined by OSHA/ANSI, to verify that the equipment is safe for use. In the event of any question or concern regarding the condition of such equipment, users shall remove the equipment from service for further inspection. All users must comply with OSHA/ANSI/ASTM standards prior to and in using such equipment. For more information regarding safe and appropriate use of equipment, please contact Buckingham Manufacturing at 1-800-937-2825.

INTERNATIONAL USERS:

Notwithstanding the above, please know that certain international jurisdictions require manufacturers of equipment to provide customers with a maximum useful lifespan (sometimes referred to as a “Statement of Obsolescence”). To the extent required, Buckingham personal protective equipment manufactured from synthetic fiber materials including but not limited to items such as webbing and/or rope are subject to a maximum useful lifespan of ten (10) years from the date of manufacture. As stated above proper usage, storage, maintenance, and care impacts the useful lifespan of equipment. Extreme circumstances may require that product must be retired after only one use. This statement is made in conformance and compliance with BS EN 365:2004. International users must ensure that product inspections are completed by Competent Persons as defined by international standards including but not limited to British Standard (“BS”). If equipment fails any inspections, it must be immediately withdrawn from service and destroyed. For more information regarding safe and appropriate use of equipment, please contact Buckingham Manufacturing at 1-800-937-2825.

OUR GUARANTEE:

We guarantee the equipment we manufacture to be free from defects in material and workmanship. We will repair any equipment deemed to be defective which is returned to us by the original purchaser. However, this guarantee is void if any product is changed or altered in any way, or if the product is used in a manner other than for which it is intended. This express guarantee supersedes all other expressed or implied guarantees, obligations or liabilities. There are no implied warranties of merchantability or fitness for a particular purpose and as such, all implied warranties are specifically disclaimed.

LIMITATION ON LIABILITY:

In no event will Buckingham or buyer be liable to the other for lost revenues, lost profits or any other indirect, consequential, special or punitive losses or damages, however caused, whether in action for breach of contract, strict liability, tort, or otherwise, even if advised of the possibility of such losses or damages. In no event will Buckingham’s liability exceed the total amount paid by the buyer to Buckingham for the product or equipment giving rise to such claim(s).

Please see other terms and conditions relating to this product at <https://buckinghammfg.com/terms-conditions/>

REGISTRATION: Before use of the product, ensure to register and confirm the product at www.buckinghammfg.com/register.

BUCKINGHAM MFG.
BINGHAMTON, NY
1-800-937-2825
e-mail - sales@buckinghammfg.com

Information contained in these written instructions supersedes all other information (written, audio, video etc.) produced by Buckingham Mfg. prior to the revision date of this document.