

BUCKINGHAM MFG

INTRODUCTION

Instructions for Use

Warning: Do not use this product if you cannot understand and follow the instructions and warnings that come with it and complete all necessary functions.

BuckRigger Swivel Pulleys Size 1.5" (38mm)

Thank you for purchasing this Buckingham Mfg. product. The BuckRigger combines a pulley with a swivel and offers tremendous advantages. It can replace a conventional pulley, carabiner & swivel and is lighter, less expensive and saves valuable vertical space. It also allows installing/removing the rope while the pulley is still anchored, which prevents dropping it & is often easier when rigging mechanical advantage systems. It does require that the user understand how it works and takes responsibility for making sure the side plates are closed & locked.

CE 0120 EN12278

Patented

Strength: In a single pulley, half the load is on one side of the rope and half is on the other. The total load on the pulley is thus 2x the mass that is being raised or lowered. In a double pulley the total load is 4x the load on the 4 individual ropes. This is illustrated on the pulley. Breaking Strength & Working Load are based on this equal loading. **If the sideplate is not fully locked by the button, the strength will be severely reduced, to about 2250 lbf. (10kN), but also, the rope may fall out.** Pulleys must be free to align with the load, **any restraint is dangerous.**

For more information, visit
Buckinghammfg.com/Patents

Working Load Limit: Is based on about a 4 : 1 safety factor. You must decide if that is sufficient in your situation or if you need to adjust the WLL.

Manufactured in **USA** using
domestic & foreign materials

	5007R1 (Single Sheave)	5007R2 (Double Sheave)
	1.5" (38mm)	1.5" (38mm)
Max Rope Strength	.5" (13mm) 8000 lbf. (36kN)	.5" (13mm) 8000 lbf. (36kN)
WLL	2000 lbf. (8.9kN)	2000 lbf. (8.9kN)
Height	5.3" (135mm)	6.4" (163mm)
Width	2.5" (63mm)	2.5" (63mm)
Thickness	1.2" (30mm)	2.25" (58mm)

Warning!



For expert use only!

- These activities are inherently dangerous and carry a significant risk of injury or death that cannot be eliminated.
- It is the user's responsibility to obtain specific training and to use it safely. These instructions DO NOT tell you everything you need to know.
- Do not use unless you can and will understand and assume all risks and responsibilities for all damage/injury/death that may result from use of this equipment, or the activities undertaken with it.
- Any device is subject to failure-carefully check before and after each use.
- You must always have a backup-never trust a life to a single tool.
- Everyone using this equipment must be given and thoroughly understand the instructions and refer to them before each use.
- You must have a rescue plan and the means to implement it. Inert suspension in a harness can quickly result in death!
- Do not use around electrical hazards, moving machinery or near sharp edges or abrasive surfaces.
- We are not responsible for any direct, indirect, or accidental consequences or damage resulting from the use of our products.
- Please consult with your physician prior to using this product. Do not use this product under the influence of drugs or alcohol.

Views shown are of the single & front side of the double. The back side of the double is reversed from these views.

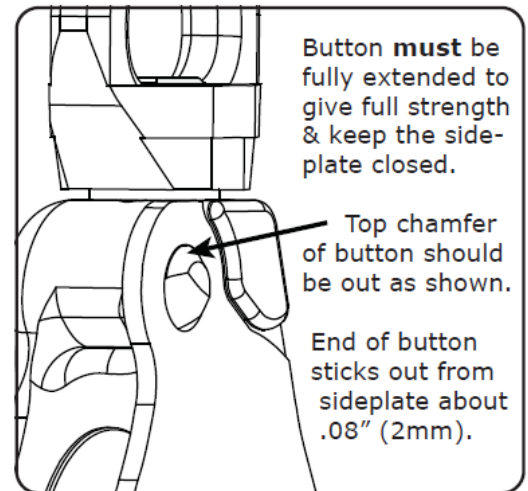
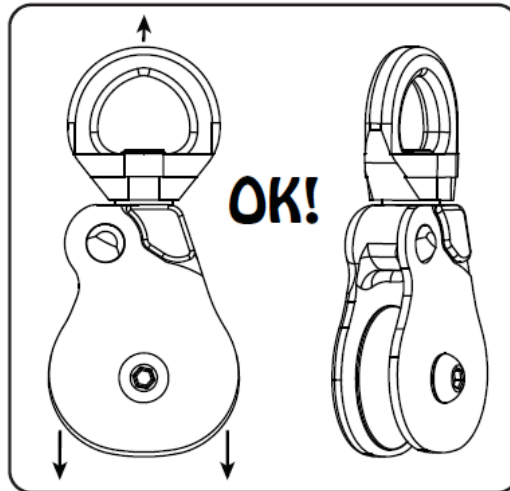

! Mandatory Locking Procedure !

The side plate must be closed and locked with the button fully extended, or strength will be greatly reduced, and the rope may fall out with catastrophic results. You must understand how the side plate & locking button work & must faithfully do the following every time you use it:

1. Visually confirm the side plate is fully closed and the locking button is fully extended.
2. Test the side plate by attempting to rotate it to confirm by touch that it is locked.

Do not allow anything to contact the button in use. Regularly check that the side plate is locked, and the pulley is positioned properly. If the pulley cannot be kept in sight, use a conventional pulley.

Buckingham Mfg. Co.
Inc.

1-11 Travis Ave.
Binghamton, NY
USA

5007R15007R2.doc
PN 230347 Rev 5/3/24

Exploded View

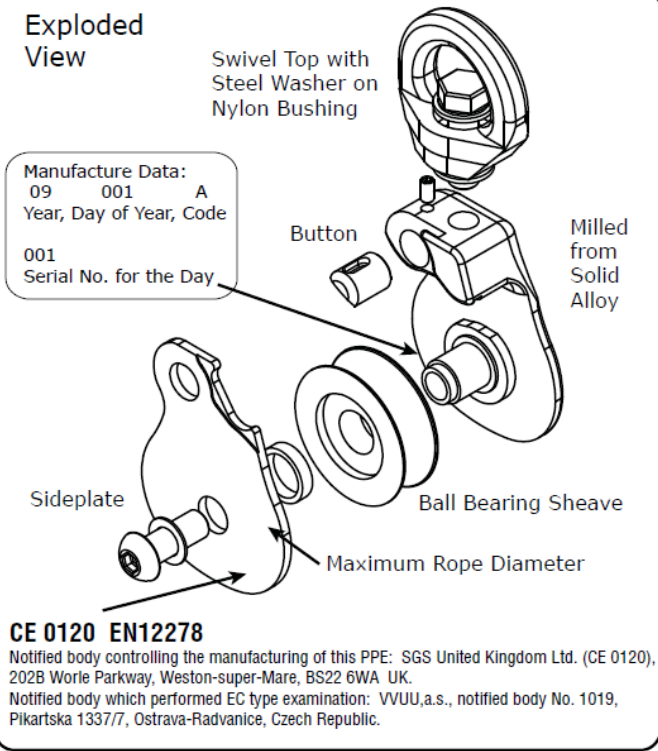

To Open Side plate

Depress the button & rotate side plate counterclockwise (clockwise for the back side of the double). It should stop at the 2nd button detent. In this position the strength is severely reduced, but the rope will not fall out as easily as it can in the fully open position. To fully open, just depress the button again & rotate.

To Close Side plate

Rotate side plate past the 2nd detent to the fully closed position. Verify the button extends fully through the hole & test that the side plate is locked & secure. You should be able to close it one-handed, but the components will last longer if you depress the button a little to help it when closing.

In Use

Do not allow anything to press button & accidentally unlock side plate. Do not allow anything to pry the side plates apart or opening or breakage may occur.

Pinching Hazard

Rope travelling through a pulley can suck in hair, fingers, clothing, etc., causing injury & jamming the pulley. Guard against this.

Inspect Before & After Use

Check all parts for cracks, deformation, corrosion, wear, etc. Verify that the side plate rotates normally & the button operates properly. The button must not be impaired by dirt, ice, corrosion, etc. Verify smooth rotation of the sheave.

Inspection During Use

Regularly inspect and monitor your system, confirming proper connections, position, fully locked side plates & fully extended buttons.

Intended Use

This Personal Protective Equipment (PPE) should only be used with energy absorbing systems such as dynamic ropes, energy absorbers, etc. & slack must be kept out of the system to prevent high impact falls. It is intended for use by medically fit, specifically trained and experienced users.

Thorough and specific training is absolutely essential before use.

Being at height is dangerous and it is up to you to reduce the risks as much as possible- but the risks can never be eliminated. There are many ways to misuse this equipment, too many to list or imagine. You must personally understand and assume all risks and responsibilities of using this equipment. If you cannot or do not want to do this, do not use this equipment.

Environmental Factors

Moisture, ice, salt, sand, snow, chemicals and other factors can prevent proper operation or can greatly accelerate wear.

Compatibility

Verify compatibility with other components of your system. Incompatible connections can cause detachment, breakage, etc.

Lifetime

BuckRiggers like all equipment must be replaced by the user at regular intervals. This interval should be dictated by the amount of use and type of service the product receives rather than a set time frame. Therefore, the manufacturer does not place a time limit on replacement of the BuckRiggers. Due to the rigorous strain the BuckRigger endures, it should be replaced at the earliest signs of wear. BuckRigger inspection is extremely important and must as a minimum be performed as stated.

Retire from Service & Destroy if it:

1. Is significantly loaded.
2. Does not pass inspection or there is any doubt about its safety.
3. Is misused, altered, damaged, exposed to harmful chemicals, etc.
4. Button fails to extend fully. Consult the manufacturer if you have any doubts or concerns.

Maintenance & Storage

Clean if necessary, with fresh water, then allow to dry completely. The button may be cleaned by holding it upside down & spraying a light lubricant into it, such as WD-40®, etc while operating it. Store in a dry place away from extremes of heat and cold and avoid chemical exposure.

Principal Material

Aluminum alloy, anodized.

Repairs or Modifications to Equipment

Are only allowed by the manufacturer or those authorized in writing by the manufacturer.

Detailed Inspection

In addition to inspection before, during and after each use, a detailed inspection by a competent inspector must be done at least every 3 months or more frequently depending on amount and type of use. Make a copy of these instructions and use one as the permanent inspection record and keep the other with the equipment. It is best to issue new gear to each user, so they know its entire history.

Stay Up To Date!

Regularly go to our website and read the latest user instructions.

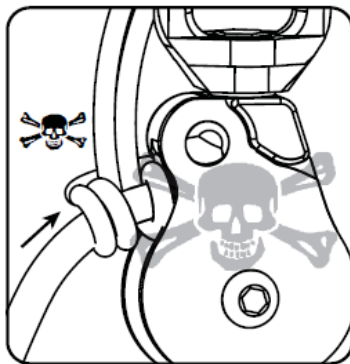
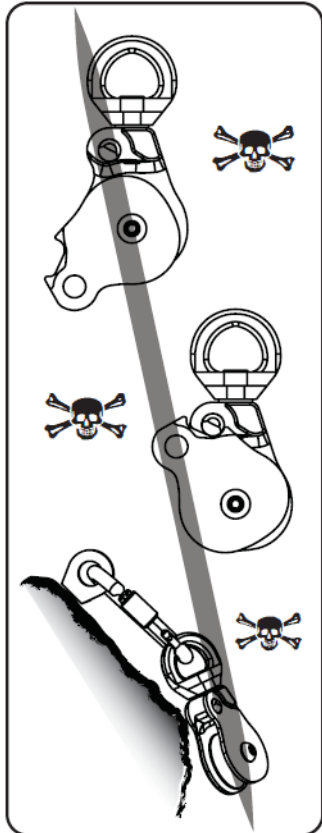

Prusik Use - Caution!

Prusiks must always have an experienced person tending them. Never allow a jammed Prusik to be pulled in between the side plates. This can bend or break the pulley and allow the rope to fall out!

Breakage Hazard

Do not let an object in between the side plates and never rig your system so that the pulley is forced against something that could break or open the side plate, allowing the rope to fall out.

Purchase Record

Purchase Record	
Model	
Complete Batch #	
Year of Manufacture	
Purchase Date	
Date of 1 st Use	
User	

Date	Condition	Inspector

STATEMENT of OBSOLESCENCE:

Precise “useful life expectancy” or “shelf life” for this product is not specified, as the degree of use, conditions of use, and the degree of care and storage determines useful life. All users maintain responsibility to select proper equipment for the job, be properly trained in its use, and ensure all personnel support equipment passes inspection before each use. Upon evidence of defects, damage or deterioration, all equipment shall be removed from service immediately and tagged or marked as unusable or destroyed. Additionally, all equipment shall be inspected on a regular basis not to exceed one year by a Competent Person, as defined by OSHA/ANSI, to verify that the equipment is safe for use. In the event of any question or concern regarding the condition of such equipment, users shall remove the equipment from service for further inspection. All users must comply with OSHA/ANSI/ASTM standards prior to and in using such equipment. For more information regarding safe and appropriate use of equipment, please contact Buckingham Manufacturing at 1-800-937-2825.

INTERNATIONAL USERS:

Notwithstanding the above, please know that certain international jurisdictions require manufacturers of equipment to provide customers with a maximum useful lifespan (sometimes referred to as a “Statement of Obsolescence”). To the extent required, Buckingham personal protective equipment manufactured from synthetic fiber materials including but not limited to items such as webbing and/or rope are subject to a maximum useful lifespan of ten (10) years from the date of manufacture. As stated above proper usage, storage, maintenance, and care impacts the useful lifespan of equipment. Extreme circumstances may require that product must be retired after only one use. This statement is made in conformance and compliance with BS EN 365:2004. International users must ensure that product inspections are completed by Competent Persons as defined by international standards including but not limited to British Standard (“BS”). If equipment fails any inspections, it must be immediately withdrawn from service and destroyed. For more information regarding safe and appropriate use of equipment, please contact Buckingham Manufacturing at 1-800-937-2825.

OUR GUARANTEE:

We guarantee the equipment we manufacture to be free from defects in material and workmanship. We will repair any equipment deemed to be defective which is returned to us by the original purchaser. However, this guarantee is void if any product is changed or altered in any way, or if the product is used in a manner other than for which it is intended. This express guarantee supersedes all other expressed or implied guarantees, obligations or liabilities. There are no implied warranties of merchantability or fitness for a particular purpose and as such, all implied warranties are specifically disclaimed.

LIMITATION ON LIABILITY:

In no event will Buckingham or buyer be liable to the other for lost revenues, lost profits or any other indirect, consequential, special or punitive losses or damages, however caused, whether in action for breach of contract, strict liability, tort, or otherwise, even if advised of the possibility of such losses or damages. In no event will Buckingham’s liability exceed the total amount paid by the buyer to Buckingham for the product or equipment giving rise to such claim(s).

Please see other terms and conditions relating to this product at <https://buckinghammfg.com/terms-conditions/>

REGISTRATION:

Before use of the product, ensure to register and confirm the product at www.buckinghammfg.com/register.