

# BUCKINGHAM MFG.

## “ErgoLite” P/N 17904, 17906 & J17904, J17906 “Alta Verde” P/N 179061 Series Saddles Instructions/Warnings

Warning: Do not use this product if you cannot understand and follow the instructions and warnings that come with it and complete all necessary functions.

The “ErgoLite” arborist saddle is designed for the professional arborist. It is fully adjustable at the waist, legs and suspension bridge to provide ease of use, comfort, adjustability, versatility and safety. The “ErgoLite” offers advantages over a conventional saddle including:

- multiple adjustments to obtain a custom fit.
  - the ability to change the length of or replace the suspension bridge.
- \* Prefix J denotes product is CE certified (EN 358-2018 & EN 813-2008) in accordance with the PPE Regulation (EU) 2016/425. The declaration of conformity is also supplied with every unit.  
\*\* Buckingham arborist saddles labeled with product numbers prefixed with H denotes product conforms to Australian standard AS/NZ 1891.1:2007 section 3.3.3

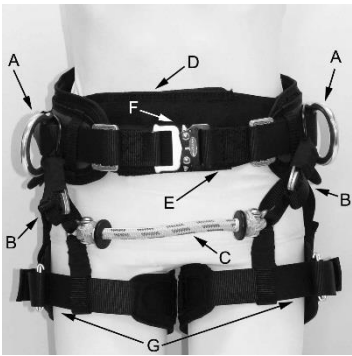

Model 17904 (rear view)



Model 17906 (rear view)

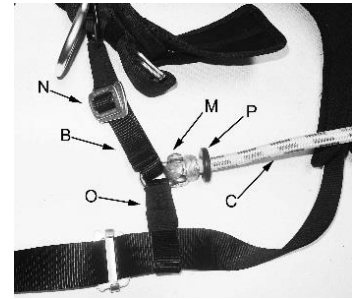

- A-Work Positioning Dee Ring
- B- Suspension Bridge Adjustment Strap
- C-Suspension Bridge
- D-Abdominal Stabilizer System
- E-Waist Belt Strap
- F-Waist Belt Quick Connect Buckle
- G-Leg Strap with Quick Connect Buckle
- H-Accessory Loops  
(PN17904 & 17906 series have 6 Loops)  
(PN179061 series has 8 Loops)
- I-Accessory Rings
- J-Leg Pad Adjustment Straps
- K- Batten Seat (Model 17904)
- K - Leg Pads (Model 17906 & 179061)
- L-Suspender Attachment Loop
- M -Clevis Shackle
- N-Interlocking Buckles
- O-Leg Pad Attachment Strap
- P- Suspension Bridge Bumpers  
(Model 1704 & 17906)
- Q- Suspension Bridge Paws (Model 179061)
- R- Full Floating Suspension Ring (Model 179061)
- S- Chainsaw attachment snaps



Model 179061 (front view)



Model 179061 (rear view)

Figure 1

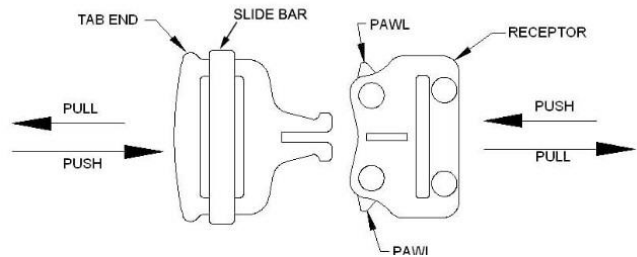

## WEARING INSTRUCTIONS:

- 1) Thoroughly inspect saddle and all related equipment before each use.
- 2) Unbuckle the waist strap and each leg strap.
- 3) Place the saddle around your waist with the waist strap buckle in the front and attach the hook and loop fastener of the Abdominal Stabilizer.

Note: Abdominal Stabilization System is for support and comfort only. Do not over tension to increase snugness of fit!! When attaching the elastic Abdominal Stabilization System, tighten the abdominal muscles by tightening the abdomen as if you were doing a crunch and then secure the hook and loop fastener. Do not hold your breath when you fasten the hook and loop fastener as this will cause over-tightening.

Figure 2

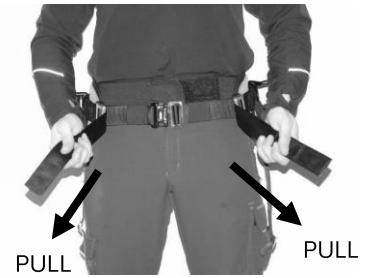

- 4) Ensure that the work positioning D-rings are slightly forward of the hip bones. Fasten the Quick Connect Buckle as shown in Figure 1. Visually inspect that the buckle is secured. Do not rely on hearing the click. Look for both sides to be locked.
- 5) Pull equally on the free ends of the waist straps until the saddle is snug on your waist as shown in Figure 2. Be sure not to over tighten as this can cause discomfort on your hips and waist.
- 6) Wrap the leg straps around the leg so that the padded portions of the leg straps are behind the leg and the buckles are on the outside of the leg.
- 7) Connect the leg strap buckles as shown in Figure 1.
- 8) Adjust the leg straps as necessary so they are snug, but comfortable.
- 9) Tuck the excess leg strap into the elastic strap keeper attached to each leg pad.

## ADJUSTMENT INSTRUCTIONS:

Once the saddle has been properly fitted, you can adjust the Suspension Bridge for optimum comfort.

- Height adjustment of the Suspension Bridge by use of the Suspension Bridge Adjustment Straps (Figure 3 ErgoLite version shown) will alter your position. Tightening the adjustment straps will move your position forward and loosening them will move it backwards.
- Proper adjustment of the Leg Pad Adjustment Straps ensures that the Leg Pads will be in the most comfortable position on your legs. Tighten the Leg Pad Adjustment Strap to raise the Leg Pad and loosen it to lower the Leg Pad.

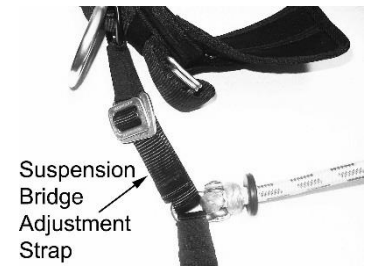

Figure 3

## REPLACING THE SUSPENSION BRIDGE

Replacement Suspension Bridges are supplied separately and include detailed replacement instructions to be used when replacing the Suspension Bridge. Use only replacement Suspension Bridges (manufactured from approved tree climbing rope) supplied by Buckingham Mfg. Use bridge PN W3-size for PN 17904 & 17906. Use bridge PN WE10 or WE10R for PN 1790671.

## Attaching the Waist Straps Instructions: (For use only when waist straps have been removed)

- 1) Lay the Back Pad inside down on a flat surface. Orientate each of the Waist Straps so that the folded & stitched tab of the webbing is facing down (tab towards the user when wearing). (Figure 4)
- 2) Angle the smaller of the two Waist Strap Adjustment Buckles and insert it through the backside of the larger Waist Strap Adjustment Buckle (Figure 5).
- 3) Pass the smaller buckle completely through the larger buckle so the smaller is lying flat on top of the larger. Be sure curves of Waist Adjustment Buckles both slope down when connected. (Figure 6a)
- 4) Ensure both ends of the webbing passes back through the larger half of the interlocking buckle as shown in Figure 6b.
- 5) Tuck the free end of the webbing over the top of the interlocking buckles and then underneath the web keeper loop attached to the back pad. (Figure 6c) Repeat for the opposite side of the waist strap.



Figure 4

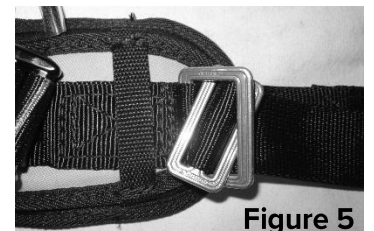

Figure 5



Figure 6a

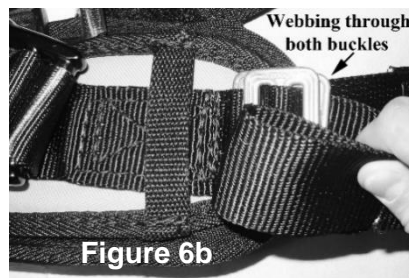

Figure 6b

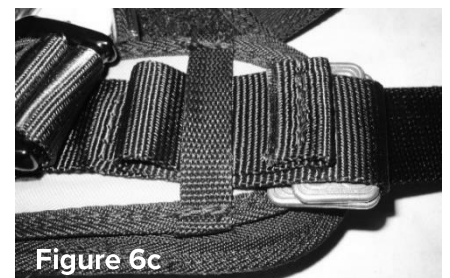
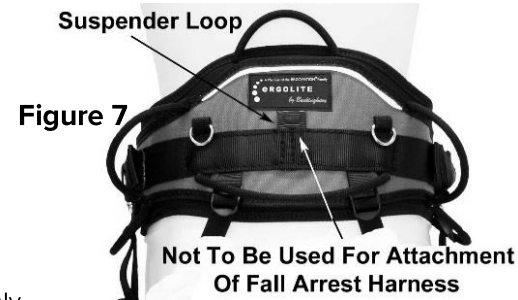

Figure 6c

## WARNINGS

- Read, understand, and follow all instructions and warnings before using this equipment. Failure to do so could result in your serious injury or death.
- This equipment is intended for use by properly trained professionals only. Do not use without proper training.
- This product is designed to be used by a person with a maximum weight of 350 lbs. (158.7 kg.) when fully equipped and medically fit for activities at height. CE approved product (prefixed with J) can be used by a person with a maximum weight of 330 lbs. (150 kg).
- Anyone with a history of back or neck problems that may be aggravated or complicated by using this equipment should not do so.
- Pregnant women and minors must not use this equipment.
- Users of this equipment must be in good health and not under the influence of drugs or alcohol.
- This saddle is not designed to be used with a retro fit Fall Arrest Harness. The large loop centered at the rear of the back pad is intended for connection of saddle suspenders only (Figure 7). Saddle suspenders **ARE NOT** safety products. Suspenders are designed to support only the weight of the saddle, and the tools it contains, **NOT** the individual.
- Buckingham arborist saddles are manufactured in accordance with the ASTM F887, EN 358 and EN 813 standards and are intended for use as personal protection equipment only, not for towing or hoisting and when properly used, comply with the requirements of the ANSI Z133-17 standard.
- Fall protection equipment, (i.e. fall arrest, work positioning belts, climbers, retrieval, suspension etc.) should not be resold or provided to others for re-use after use by original user as assurance cannot be granted that a used product meets criteria of applicable standards and is safe for use to a subsequent user.
- Before use the first time, the user should carry out a suspension test in a safe place to ensure that the equipment is the correct size, has sufficient adjustment and is of an acceptable comfort level for the intended use.
- Before use of the equipment, consideration should be given as to how any necessary rescue could be safely achieved.
- This product is to be used for positioning and suspension only, **NOT FOR FALL ARREST**. Therefore, it may be necessary to supplement arrangements for work positioning / suspension with collective means (i.e. safety nets) or personal means of protection against falls from a height (i.e. fall arrest system). A fall arrest harness is the only device allowable for supporting the body in a fall arrest system.



- This equipment must only be used for the specific purpose for which it is designed and intended (Figure 8).
- Destroy any and all equipment subjected to impact loading.
- Never work without independent fall arrest protection if **there is danger of a fall**.
- Keep equipment from coming into contact with sharp or abrasive edges, electrical conductivity, extreme temperatures, excessive ultraviolet rays and chemical agents. Exposure to these elements may have a detrimental effect on the integrity of the equipment. Sharp and abrasive surfaces may include but not be limited to (sheet metal, steel, concrete, block, stone, laminated materials etc.)
- Always visually check that all buckles are properly closed before use. (If making a connection to a point that cannot be seen by the wearer, either ensure the connection is made before donning the equipment or the connection is made and checked for security by a second person).
- Attach only connecting devices i.e. snap hook/ carabiner meeting standards/regulations for intended use for positioning and suspension to belt D-rings and Suspension Bridge (see figure 8).
- Only positioning connecting devices should be attached to side D-rings, as side D-rings are not intended for fall arrest.
- Only suspension connecting devices should be attached to Suspension Bridge as Suspension Bridge is not intended for fall arrest or positioning.
- Position and / or adjust the work positioning lanyard in such a manner that the anchorage point is maintained at or above waist level.
- As outlined by OSHA 1926.502 (e)(2) positioning devices shall be secured to an anchorage capable of supporting at least twice the potential impact load of an employee's fall or 3,000 lbf. (13.3 kN), whichever is greater versus fall arrest anchor points which must support a minimum of 5,000 lbf. (22.2 kN) per attached worker and be Independent of worker support.
- Always visually check that each connecting device i.e. snap hook / carabiner freely engages D-ring, Suspension Bridge or anchor point and keeper / gate is completely closed with each use. **Never** rely solely on the feel or sound of a connecting device i.e. snap hook/ carabiner engaging. (If making a connection to a point that cannot be seen by the wearer, either ensure the connection is made before donning the equipment or the connection is made and checked for security by a second person).
- Before each use check that: 1) fabric or belt strap is free of burns, cuts, broken stitches or excessive wear, 2) rivets are not bent, loose or missing, 3) buckles and D-rings are not distorted or cracked, 4) if there is a tongue buckle, that the tongue does not bind on the buckle and buckle holes are not damaged. Always remove from service, destroy and discard product if it fails inspection. Your safety is related to the integrity of your equipment.
- Ensure that this product is compatible with the other elements of the system. Ensure all associated elements of the system are equivalently rated for use in conjunction with the saddle and each other. Ensure and that the safe function of any one item of the system will not affect or interfere with the safe function another. Failure to do so could result in injury or death.
- When in the work position, ensure there is no pressure on the snap hook locking mechanism sufficient to depress it as this will, due to its length, render it incompatible with currently designed D-rings and make it very susceptible to rollout.

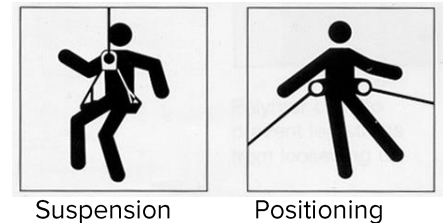

- During use all fastening and adjusting elements must be regularly checked to ensure adjustment and closure.
- Unless using locking snaphooks / carabiners designed for such connections never attach multiple snap hooks to a D-ring.
- Never disable locking keeper on snap hook or carabiner.
- Accessory / gear loops must only be used to attach and carry equipment such as carabiners, first aid pouch, etc. Never attach support / suspension connections to gear loops (Figure. 9a & 9b) !
- Designated slots in the webbing can accommodate accessory carabiners. Heavy equipment such as chainsaws should be attached to these accessory carabiners which are supported by load bearing webbing (Figure. 9a & 9b).
- PN 179061 series has been designed with chainsaw attachment snaps attached to load bearing webbing (see page 1).
- Never punch additional holes in or alter any belt or harness in any way.
- This equipment should be a personal issue to the employee using it.
- Only Buckingham Mfg. Co. or those people authorized in writing by Buckingham Mfg. Co. may make repairs / modifications to this equipment.
- Documentation containing the following information should be issued with and kept for each sit harness (saddle): identification marks, manufacturer's or suppliers name and address, manufacturer's serial number (if applicable), date of manufacture, suitability for use with other components within personal fall arresting systems, date of purchase, date first put into service, dates and details of periodic inspections, next due date of periodic inspection, name of competent person who carried out periodic inspection, user name and space for comments.
- **Employer** - instruct your employees as to proper use, warnings and cautions before use of this equipment.
- Product covered under these instructions / warnings should not be resold / redistributed or re-used after use by original user.
- It is essential for the safety of the user that, if this product is re-sold outside the original country of destination, the reseller shall provide instructions for use, for maintenance, for periodic examination and repair in the language of the country in which the product is to be sold.
- Suspension Trauma (also called Orthostatic Intolerance) is the loss of consciousness due to a victim being held upright with limited movement for a period of time, which can rapidly lead to death if not properly recognized and treated. Suspension Trauma can be controlled with good product design, prompt rescue, and post fall suspension relief devices. A conscious user may deploy a suspension relief device allowing the user to remove tension from around the legs, freeing blood flow, which can delay the onset of suspension intolerance.



**Figure 9b**

### When To Retire Your Equipment:

Personal protective equipment is designed to be replaced by the user at regular intervals. This interval should be dictated by the type and amount of use the product receives rather than a set time frame. Therefore the manufacturer does not place a time limit on the replacement of this saddle. Extreme circumstances may require that a product must be retired after only one use. Consideration must be given to the type, intensity and the environment of usage (harsh environments, marine environment, sharp edges, extreme temperatures, chemical products, improper storage, etc).

As a minimum these saddles must be retired when:

- they have been subjected to a major fall (impact loading).
- they fail to pass inspection or you have any doubt as to their reliability.
- You are unsure of the full usage history of the saddle.
- When they become obsolete due to changes in regulations, standards, technique, or they become incompatible with other equipment.

Destroy all retired equipment to prevent further use.

### Additional Instructions / Warnings for Quick Connect Buckle

#### For your information and attention:

Quick Connect Buckles on those Full Body Harnesses and Arborist's Saddles that include this style of buckle may unintentionally disengage under the condition outlined below:

If the pawls of the buckle do not freely rotate, proper engagement of the tab end to the receptor end of the buckle will be hindered / restricted. If as a result of the users movements or through contact with an obstruction during the course of his/her work, one of the two pawls of the receptor end of the buckle is depressed while tension is induced on the strapping attached to the buckle, the potential exists that disengagement of the tab end of that side from the pawl may occur. If that position is maintained and again through the users movements or contact with an obstruction the opposite side pawl is depressed, the tab end of the buckle may totally disengage from the receptor end.

#### To eliminate the potential for this condition, you the user should:

1. Inspect your equipment before each use as you would for all safety equipment. Equipment should be replaced if you have any question / doubt about it being safe for use.

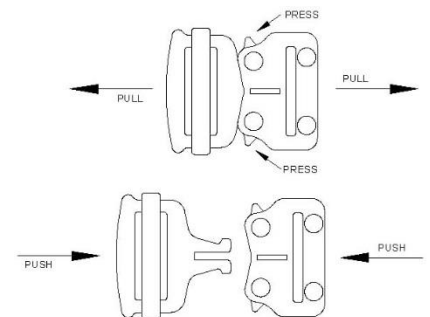

2. Always position the buckles of your equipment so that contact with obstructions is avoided.
3. Test the pawls on your Quick Connect Buckles to ensure they freely rotate and return back to their original position. If any pawl does not freely rotate, the buckle should be (a) cleaned as outlined below to ensure there are no obstructions inside the buckle hindering its intended function and (b) lubricated with a lightweight lubricant such as BuckLube™, WD-40®, etc as recommended for locking snaphooks. If the pawl still does not freely rotate, you should contact Buckingham Mfg. at the telephone number outlined below and request a Returned Goods Authorization Number for immediate return of your harness or Arborists Saddle for our inspection and/or buckle replacement.
4. Ensure the receptor end and tab end of the Quick Connect Buckle is fully connected with both locking pawls engaged. When the two halves are properly attached together, a clicking sound should be heard. Complete by pulling the adjuster strap through the buckle and tighten until it is snug but comfortable, thus ensuring complete engagement.

**Cleaning Instructions:** The Quick Connect Buckle may be cleaned by using a cotton swab, limited air pressure or dipping it into a container of water to remove fine particles and any foreign matter which may enter the receptor end of the buckle and preventing proper engagement and function. The exterior of the buckle should be dried with a clean cloth. The inside of the receptor end of the buckle should be air-dried and re-lubricated.

**Maintenance:** Lubricate pawls weekly or as often as required to maintain smooth operation (no binding) with a lightweight lubricant such as BuckLube™, WD-40®, etc. Wipe any excess lubricant off with a clean dry cloth. Buckingham's primary concern is to provide a quality product to its customers to enable them to carry out their profession in a safe manner. However, we always require our customer's assistance in proper equipment operation, inspection, and maintenance.

### Additional Instructions / Warnings for Suspension Bridge:

The Rope Suspension Bridge attached to this saddle is designed to be replaced by the user at regular intervals. This interval should be dictated by the amount of use the product receives rather than a set time frame. Therefore the manufacturer does not place a time limit on replacement of the suspension bridge. Due to the rigorous strain the Rope Suspension Bridge endures, it should be replaced at the earliest signs of wear. Suspension bridge inspection is extremely important and must be performed prior to each use. This inspection should include but not be limited to:

webbing and rope cuts, nicks, tears, kinks, abrasions, burns, excessive swelling, excessive wear, discoloration, cracks, charring, broken, fraying or unraveling fibers, loose stitching chemical or physical exposure.

Failure to regularly inspect and replace the Rope Suspension Bridge could result in injury or death due to Suspension Bridge failure.

Note: Only authorized replacement parts from Buckingham Mfg. should be used on this product. The use of unauthorized replacement parts will void Buckingham Mfg's Warranty.

**SIZING** - Fit is important to comfort. Be sure to allow for wear over heavy clothing. In order to obtain an optimum fit, the work positioning D-rings should be positioned slightly forward of the hip bones. Below are typical fits given according to waist size.

X-Small (XS) = 24 -28" (610 - 711 mm) waist size	Large (L) = 36-40" (914-1016 mm) waist size
Small (S) = 28 - 32" (711-813 mm) waist size	X-Large (X) = 40-44" (1016-1118 mm) waist size
Medium (M) = 32-36" (813-914 mm) waist size	

**NOTE:** Ensure proper fit / size of product before use. This product cannot be returned unless it is in new unused condition.

**Inspection:** Prior to each use, carefully inspect this equipment for indications of wear or deterioration. The inspection, should include but not be limited to inspection for:

- webbing cuts, kinks, abrasions, burns, excessive swelling, excessive wear, discoloration, cracks, charring, broken fibers, loose, s cut, or missing stitching, absence, or illegibility of markings, chemical or physical exposures.
- buckle holes in strap are not damaged.
- loose, bent or pulled rivets, bent grommets, and broken, cut, or burned threads.
- tongue of buckle (if equipped) does not bind on buckle frame.
- nicks, cracks, distortion or corrosion of hardware (buckle, D-rings, etc.).

An additional inspection shall be performed by a competent person other than the user at an interval of no more than one year. The frequency of periodic inspection by a competent person shall be established by the users organization based on careful consideration of relevant factors. Such factors include the nature and severity of workplace conditions affecting the equipment and the modes of use and exposure time of the equipment. If any evidence of wear or deterioration as outlined is observed, immediately cease use, destroy the product and replace it with new equipment. Should any unusual conditions not outlined above be observed, or you have reasonable doubt about a particular condition, remove the equipment from service and notify your Supervisor, Safety Director or contact Buckingham Mfg. (1-800-937-2825) for clarification. Failure to carefully and completely inspect your equipment could result in serious injury or death.

## Properties of Arborist saddle Materials

Material	Effect of Heat	Effect of Acids & Alkalis	Effect of Bleaches & Solvents	Resistance to Mildew, Aging, Sunlight, Abrasion
Polyester	Sticks at 440 to 445° F. Melts at 482° F.	Good resistance to most mineral acids. Dissolves with partial decomposition in concentrated solution of sulfuric acids. Good resistance to weak alkalis. Moderate resistance to strong alkalis at room temperature. Disintegrates in strong alkalis at boil.	Excellent resistance to bleaches & other oxidizing agents. Generally insoluble except in some phenolic compounds.	Not weakened by mildew. Excellent resistance to aging & abrasion. Prolonged exposure to sunlight causes some strength loss.
Nylon 6	Melts at 419 to 430° F. Slight discoloration at 300° F when held for 5 hr. Decomposes at 600 to 730° F.	Strong oxidizing agents & mineral acids cause degradation. Others cause loss in tenacity & elongation. Resists weak acids. Soluble in formic & sulfuric acids. Hydrolyzed by strong acids at elevated temperatures. Substantially inert in alkalis.	Can be bleached in most bleaching solutions. Generally insoluble in organic solvents. Soluble in some phenolic compounds.	Excellent resistance to mildew, aging & abrasion. Prolonged exposure to sunlight causes some degradation.

### CLEANING, STORAGE and TRANSPORTATION

Principal materials:

Straps: nylon, polyester.

Adjustment buckles: steel.

Work positioning D-rings: aluminum alloy.

Proper maintenance, storage and transportation of your equipment will prolong its useful life and contribute toward its performance. Nylon and polyester should be cleaned and disinfected with water and mild soap and be allowed to air dry thoroughly without using excessive heat. Do not use any type of corrosive substance or acid, which will gradually deteriorate the fabric. Steel and aluminum components may be wiped clean with a cloth dampened with a lightweight lubricant such as BuckLube™, WD-40®, etc. Your equipment should be stored and transported so that it does not come into contact with moisture, ultra violet rays, extreme temperatures, or chemical agents. Warnings pertaining to cleaning, storage and transportation should be strictly adhered to. To aid in protecting the hardware from rusting, it is recommended that the hardware be treated with BuckLube™, WD-40 Multi-Use Product or Hilco Lube lubricant cleaner at regular intervals.

#### Rust on Saddle Hardware (hardware styles may vary)

If through regular product inspection you note rust on hardware, the severity of the rust will determine whether the saddle is deemed usable or unacceptable and recommended for removal from service. Below are examples of hardware rust exposure deemed acceptable for keeping the saddle in service or unacceptable and recommended to cease use.

#### Slight/Moderate [Acceptable]: White Scale / Oxidation and Surface Rust

Single Slot



Slight

2 Slot



Slight

QC buckle



Moderate

Buckingham recommends cleaning hardware in this condition using an ultrafine Scotch Brite scouring pad (3M part number 14049 available at distributors such as Grainger), cut to approximately a 1" x 1" square, and with BuckLube™, WD-40 Multi-Use Product or Hilco Lube lubricant cleaner (also available at retail distributors such as Grainger), scrub the areas that exhibit rust in a back and forth motion until all surface rust has been removed.

#### Severe [Unacceptable]: Pitting / Excessive Red Rust

Single Slot



Severe

2 Slot



Severe

QC buckle



Severe

Note: Hardware in this condition is recommended for removal from service.

\*Dee rings are not shown above but shall follow the same Rust on Saddle Hardware criteria as shown above\*

Please contact your Buckingham Customer Service Representative at 800-937-2825 should you have any questions as to condition of the hardware or your product.

**CE CERTIFICATION ISSUED BY:**

INSPEC INTERNATIONAL B.V.  
BEECHAvenue 54-62  
1119 PW SCHIPOL-RIJK  
NETHERLANDS  
NOTIFIED BODY No. 2849

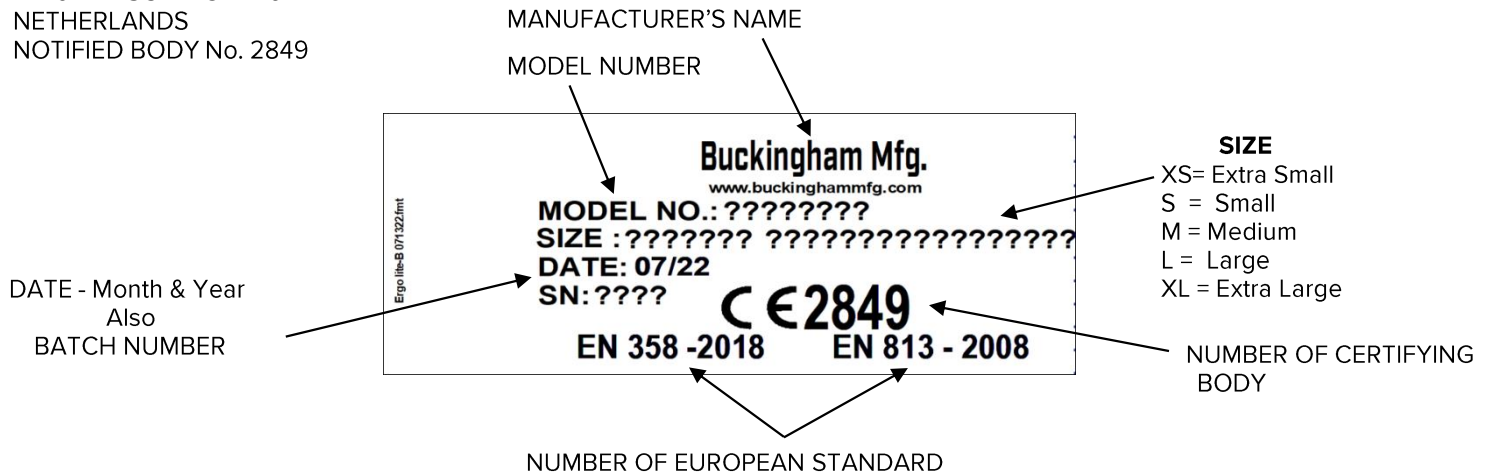

**STATEMENT of OBSOLESCENCE:**

Precise “useful life expectancy” or “shelf life” for this product is not specified, as the degree of use, conditions of use, and the degree of care and storage determines useful life. All users maintain responsibility to select proper equipment for the job, be properly trained in its use, and ensure all personnel support equipment passes inspection before each use. Upon evidence of defects, damage or deterioration, all equipment shall be removed from service immediately and tagged or marked as unusable or destroyed. Additionally, all equipment shall be inspected on a regular basis not to exceed one year by a Competent Person, as defined by OSHA/ANSI, to verify that the equipment is safe for use. In the event of any question or concern regarding the condition of such equipment, users shall remove the equipment from service for further inspection. All users must comply with OSHA/ANSI/ASTM standards prior to and in using such equipment. For more information regarding safe and appropriate use of equipment, please contact Buckingham Manufacturing at 1-800-937-2825.

**INTERNATIONAL USERS:**

Notwithstanding the above, please know that certain international jurisdictions require manufacturers of equipment to provide customers with a maximum useful lifespan (sometimes referred to as a “Statement of Obsolescence”). To the extent required, Buckingham personal protective equipment manufactured from synthetic fiber materials including but not limited to items such as webbing and/or rope are subject to a maximum useful lifespan of ten (10) years from the date of manufacture. As stated above proper usage, storage, maintenance, and care impacts the useful lifespan of equipment. Extreme circumstances may require that product must be retired after only one use. This statement is made in conformance and compliance with BS EN 365:2004. International users must ensure that product inspections are completed by Competent Persons as defined by international standards including but not limited to British Standard (“BS”). If equipment fails any inspections, it must be immediately withdrawn from service and destroyed. For more information regarding safe and appropriate use of equipment, please contact Buckingham Manufacturing at 1-800-937-2825.

## **OUR GUARANTEE:**

We guarantee the equipment we manufacture to be free from defects in material and workmanship. We will repair any equipment deemed to be defective which is returned to us by the original purchaser. However, this guarantee is void if any product is changed or altered in any way, or if the product is used in a manner other than for which it is intended. This express guarantee supersedes all other expressed or implied guarantees, obligations or liabilities. There are no implied warranties of merchantability or fitness for a particular purpose and as such, all implied warranties are specifically disclaimed.

## **LIMITATION ON LIABILITY:**

In no event will Buckingham or buyer be liable to the other for lost revenues, lost profits or any other indirect, consequential, special or punitive losses or damages, however caused, whether in action for breach of contract, strict liability, tort, or otherwise, even if advised of the possibility of such losses or damages. In no event will Buckingham's liability exceed the total amount paid by the buyer to Buckingham for the product or equipment giving rise to such claim(s).

Please see other terms and conditions relating to this product at <https://buckinghammfg.com/terms-conditions/>

## **REGISTRATION:**

Before use of the product, ensure to register and confirm the product at [www.buckinghammfg.com/register](http://www.buckinghammfg.com/register).

**BUCKINGHAM MFG.**  
**BINGHAMTON, NY**  
**1-800-937-2825**  
**[www.buckinghammfg.com](http://www.buckinghammfg.com)**