

BUCKINGHAM MFG.

CUSHION WRAP PADS

Warning: Do not use this product if you cannot understand and follow the instructions and warnings that come with it and complete all necessary functions.

Buckingham Cushion Wrap Pads are manufactured in various configurations including straight or angled tunnels (Fig. 1), 3" or 4" pad widths, Cinch Style Pads (pads with a steel loop) or Wrap style pads (without a steel loop).

Fig. 1

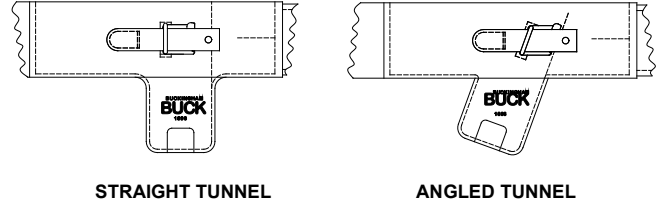

CINCH STYLE PADS (Pads with steel loop)

MODEL NUMBERS: 3500C, 3500CS, 3502C, 3502CKL, 35021C, 3503C & 3504C

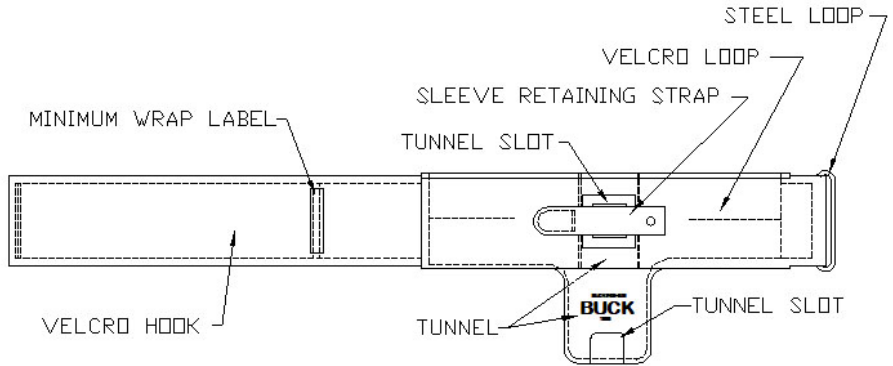
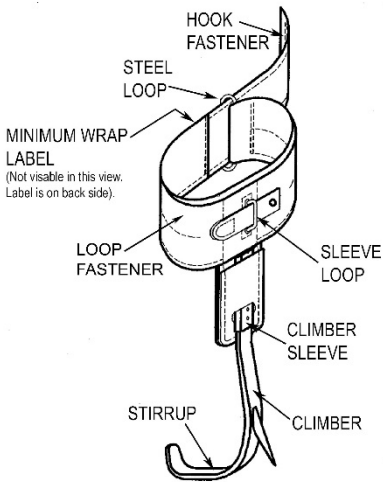

WRAP STYLE PADS (Pads without steel loop)

MODEL NUMBERS: 3500, 3502, 3502KL, 35021, 3503 & 3504

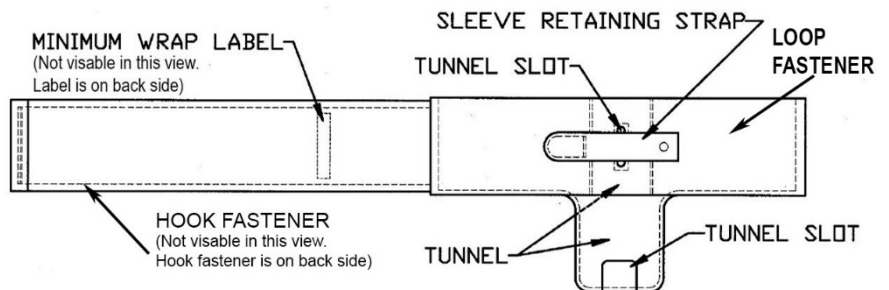
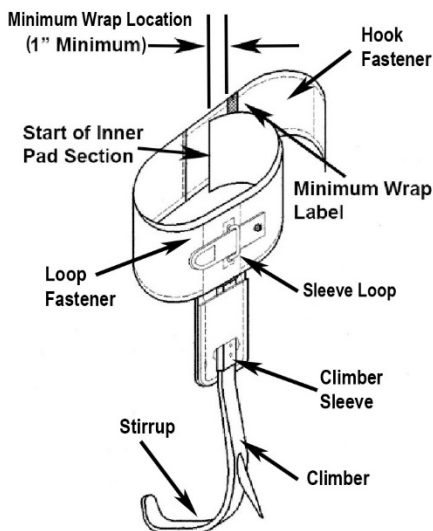

INSPECTION

Cushion wrap pads must be inspected before each use. Inspect to ensure the pads are properly attached and in good condition, have no broken stitching, rivets, or loops.

If any evidence of excessive wear or deterioration as outlined is observed, immediately cease use, destroy the product, and replace it with new equipment. Should any unusual conditions not outlined above be observed, or you have reasonable doubt about a particular condition, remove the equipment from service and notify your Supervisor, Safety Director, or contact Buckingham Mfg. (1-800-937-2825) for clarification.

Failure to carefully and completely inspect your equipment could result in serious injury or death.

Product covered under these instructions / warnings should not be resold / redistributed or re-used after use by original user as assurance cannot be granted that a used product meets criteria of applicable standards and is safe for use to a subsequent user.

Ensure proper fit / size of product before use. This product cannot be returned unless it is in new / unused condition.

ASSEMBLING PAD TO CLIMBER

1. Squeeze the pad so the tunnel protrudes outward, away from the pad.
2. Push the sleeve (attached to climber) from the bottom upward until the sleeve loop is exposed in the tunnel slot. The tunnels and slots are made for a snug fit, twisting the climber on an angle will ease the climber shank insertion into the tunnel slot of the pad.
3. To ease weaving the sleeve retaining strap under the sleeve loop, first slide a piece of paper through the sleeve loop. Then slide the sleeve retaining strap under the sleeve loop. The paper will prevent the hook fastener on the strap from catching on the loop fastener of the pad. Pull paper and sleeve retaining strap through the sleeve loop together.
4. Remove the paper, attach the hook and loop fastener strap to the pad and you are now ready to attach pad to leg.

ATTACHING CINCH STYLE PAD TO LEG

1. Place your foot on the stirrup of the climber. The padded, leather portion of the pad should be toward the inside of the leg.
2. Adjust the length of the climber using the adjustable climber sleeve so that the top of pad is 1/2" below the projecting knee bone (Fig. 2).
3. To secure the pad to the leg, begin by threading the free end of the pad through the steel loop (Fig. 3).
4. Continue to pull the end of the pad through the steel loop until the pad is snug to the leg but never so tight as to restrict circulation. Always ensure that the **MINIMUM WRAP LABEL** has been pulled completely through the steel loop (Fig. 4 and Fig. 5). Wrap the free end around the pad, adhering the hook fastener to the loop fastener on the body of the pad (Fig. 5). This ensures a proper wrap. Failure to do so may cause release, resulting in serious injury or death.

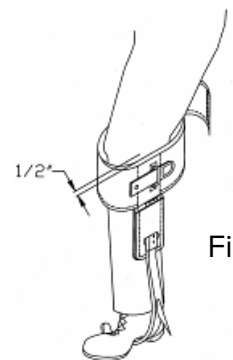

Fig. 2

Note: Do not use product if the minimum wrap label does not properly protrude through the steel loop as instructed above. Contact Buckingham Mfg. for an alternate option.

5. Cushion wrap pads must always be used in combination with correctly fastened climber foot straps to properly attach climbers to your legs. Never use a cushion wrap pad without a climber foot strap.

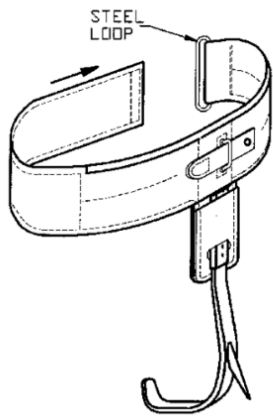

Fig. 3

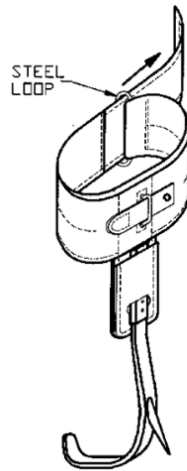

Fig. 4

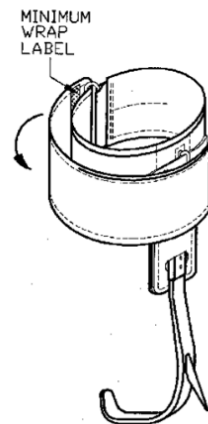

Fig. 5

ATTACHING WRAP STYLE PAD (WITHOUT STEEL LOOP) TO LEG

1. Place your foot on the stirrup of the climber. The padded, leather portion of the pad should be toward the inside of the leg.
2. Adjust the length of the climber using the adjustable climber sleeve so that the top of pad is 1/2" below the projecting knee bone (Fig. 6).
3. Wrap the pad (hook fastener portion) around the leg until the pad is snug to the leg but never so tight as to restrict circulation. Ensure the MINIMUM WRAP LABEL is located at least 1" past the start of the inner pad section or beyond (Fig. 7) and adhere it to the loop fastener portion. This ensures a proper wrap. Failure to do so may cause release, resulting in serious injury or death.
4. Cushion wrap pads must always be used in combination with correctly fastened climber foot straps to properly attach climbers to your legs. Never use a cushion wrap pad without a climber foot strap.

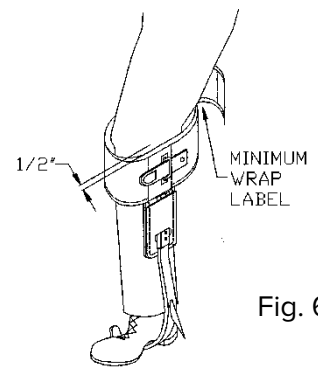

Fig. 6

Note: Do not use product if the minimum wrap label cannot be pulled at least 1" past the start of the inner pad section. Contact Buckingham Mfg. for alternate option.

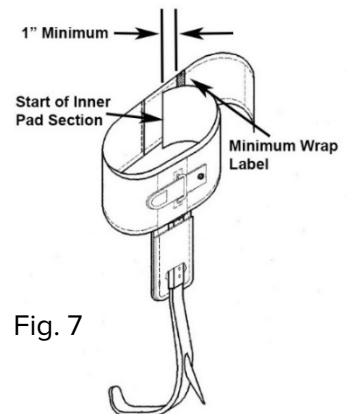

Fig. 7

CLEANING

Proper maintenance and storage of your equipment will prolong its useful life and contribute toward its performance.

Nylon should be cleaned with mild soap and water and be allowed to air dry thoroughly without using excessive heat. Do not use any type of corrosive substance or acid, which will gradually eat away the fabric.

Clean hook & loop fasteners with a soft bristle brush.

Clean leather by removing surface dirt with a clean cloth dampened (not wet) with water and allow to air dry.

WARNINGS

- Completely read, understand, and follow all instructions, warnings, and guidelines pertaining to this and all associated equipment before use. Failure to do so could result in your serious injury or death.
- Buckingham climber pads are not intended for, and not be used by, individuals not properly trained. Use by such persons could cause a fall and result in serious injury or death.
- Use equipment for its intended purpose only.
- Only Buckingham Mfg. Co. or those people authorized in writing by Buckingham Mfg. Co. may make repairs / modifications to this equipment.
- Climber accessories must be in good condition. Material shall be kept clean and leather shall be properly oiled. Climbing equipment that shows signs of excessive wear, or cracking of components, should be immediately discarded.
- No equipment lasts forever. Therefore, should you have any doubt about the safety of your equipment, replace it.

STATEMENT OF OBSOLESCENCE:

Precise “useful life expectancy” or “shelf life” for this product is not specified, as the degree of use, conditions of use, and the degree of care and storage determines useful life. All users maintain responsibility to select proper equipment for the job, be properly trained in its use, and ensure all personnel support equipment passes inspection before each use. Upon evidence of defects, damage or deterioration, all equipment shall be removed from service immediately and tagged or marked as unusable or destroyed. Additionally, all equipment shall be inspected on a regular basis not to exceed one year by a Competent Person, as defined by OSHA/ANSI, to verify that the equipment is safe for use. In the event of any question or concern regarding the condition of such equipment, users shall remove the equipment from service for further inspection. All users must comply with OSHA/ANSI/ASTM standards prior to and in using such equipment. For more information regarding safe and appropriate use of equipment, please contact Buckingham Manufacturing at 1-800-937-2825.

INTERNATIONAL USERS:

Notwithstanding the above, please know that certain international jurisdictions require manufacturers of equipment to provide customers with a maximum useful lifespan (sometimes referred to as a “Statement of Obsolescence”). To the extent required, Buckingham personal protective equipment manufactured from synthetic fiber materials including but not limited to items such as webbing and/or rope are subject to a maximum useful lifespan of ten (10) years from the date of manufacture. As stated above proper usage, storage, maintenance, and care impacts the useful lifespan of equipment. Extreme circumstances may require that product must be retired after only one use. This statement is made in conformance and compliance with BS EN 365:2004. International users must ensure that product inspections are completed by Competent Persons as defined by international standards including but not limited to British Standard (“BS”). If equipment fails any inspections, it must be immediately withdrawn from service and destroyed. For more information regarding safe and appropriate use of equipment, please contact Buckingham Manufacturing at 1-800-937-2825.

OUR GUARANTEE:

We guarantee the equipment we manufacture to be free from defects in material and workmanship. We will repair any equipment deemed to be defective which is returned to us by the original purchaser. However, this guarantee is void if any product is changed or altered in any way, or if the product is used in a manner other than for which it is intended. This express guarantee supersedes all other expressed or implied guarantees, obligations or liabilities. There are no implied warranties of merchantability or fitness for a particular purpose and as such, all implied warranties are specifically disclaimed.

LIMITATION ON LIABILITY:

In no event will Buckingham or buyer be liable to the other for lost revenues, lost profits or any other indirect, consequential, special or punitive losses or damages, however caused, whether in action for breach of contract, strict liability, tort, or otherwise, even if advised of the possibility of such losses or damages. In no event will Buckingham's liability exceed the total amount paid by the buyer to Buckingham for the product or equipment giving rise to such claim(s).

Please see other terms and conditions relating to this product at <https://buckinghammfg.com/terms-conditions/>

REGISTRATION:

Before use of the product, ensure to register and confirm the product at www.buckinghammfg.com/register.

BUCKINGHAM MFG.

BINGHAMTON, NY

1-800-937-2825

Fax 607-773-2425

e-mail - sales@buckinghammfg.com

Information contained in these written instructions supersedes all other information (written, audio, video etc.) produced by Buckingham Mfg. prior to the revision date of this document.